

Underwater Photography

Jan/Feb 2015
Issue 82



Remote, yet accessible

At Wakatobi, getting away from it all is easy. Direct charter flights whisk you from Bali to our remote island retreat, where your beachfront Bungalow or Villa awaits, and some of the finest and best-protected reefs in the world are at your door.

Far removed from the day-to-day, you are free to create your own schedule, taking full advantage of the many daily opportunities to immerse in one of the world's richest underwater environments, or simply relax in an idyllic oceanfront environment at a resort known for providing the highest level of personal service.

Colorful reefs, which plunge dramatically from shallow depths, give snorkelers plenty to see and also allow for long multi-level dives of an hour or more. Within our private marine sanctuary, marine life thrives – more than 600 species of coral, 3,000 varieties of fish and thousands more invertebrates. Our expansive House Reef and the nearby 40-plus dive sites provide endless possibilities for discovery. Those seeking even more adventure can combine a stay at the resort with a cruise aboard the luxury dive yacht Pelagian, which ranges farther afield.

Getting to and from the resort has never been easier: our charter flight schedule has recently expanded to provide even greater flexibility in planning your travel itineraries. Our concierge staff manages all aspects of airport transfers in Bali, and can help create memorable layovers before or after your visit to Wakatobi.

Get away from it all. Discover the possibilities at www.wakatobi.com or contact us at office@wakatobi.com.



"Exceptional service in every aspect of my time spent at Wakatobi. After three visits of multiple weeks I only find myself wanting more. Go Go Go to Wakatobi as it truly is an amazing experience!"

Troy Cheek, October 2014



wakatobi

www.wakatobi.com



Contents

- 4 Editorial
- 5 News Travel & Events



- 12 New Products



- 30 Edward Lai interview
by Peter Rowlands



Cover shot by
Alex Mustard

- 36 Nauticam Nikon D750
by Alex Mustard



- 41 Flip snoot pro
by Dan Bolt



- 45 DeepPro GoPro
by Ron Lucas

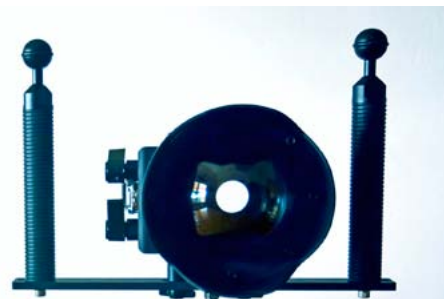

Underwater Photography

A web magazine Uwp82 Jan/Feb 2015

- 50 Stills to video
by Rob Duncan



- 53 Storytelling
by Eric Hanauer



- 59 Lembeh workshop
by Paul Macdonald



- 62 Gulf Gobies
by Alex Tyrell



- 69 SouthWest Ramblings 11
by Mark Webster



- 74 Book Review
by Dan Bolt

- 78 Parting Shot
by Peter Rowlands



Underwater Photography 2001 - 2015
© PR Productions
Publisher/Editor Peter Rowlands
www.pr-productions.co.uk
peter@uwpmag.com

Video in print

There's no doubt that with the marketing hype behind 4k, video is the new hot potato but discussing it in all its facets is actually quite difficult in a 'printed' magazine.

Despite being in the digital age there are still lots of conventional magazines dedicated to photography where still images and the techniques behind them are displayed in print and discussed in the written word. The moving image - or video- however has been almost impossible to feature successfully in print because pages can't include video clips.

In a funny sort of a way UwP is rather like a conventionally printed magazine in that it too is limited as to how it can convey and discuss video footage and techniques. Sure we could embed video clips to go with the text but that would make the downloadable file size far too big which would take away from UwP's advantage.

The perfect domain for video is the web with sites like YouTube where you can link to them or even embed their link as being the best way to discuss and illustrate everything from storyboarding to shooting to editing with actual moving examples on screen.

That doesn't mean that UwP can't feature video and 2 articles

Editorial

in this issue confirm just that. Rob Duncan has written a very informative account of the transition from shooting video as opposed to stills and Eric Hanauer discusses the vital ingredient of any successful video clip be it 1 minute or 50 minutes long - storytelling.

Enjoy.

Balance and buoyancy

Believe it or not I was recently asked "How do you get your video footage to be so steady?" and once my artistic ego has shrunk to normal again I explained that balance and buoyancy are the basic ingredients for success and they apply equally well to stills as well as video shooters.

With video my personal preference is to get the balance of my system - housing, arms and lights - to be ever so slightly negative underwater and that, ideally, if you were to let go of it, it would ever so slowly sink but remain level. That can be achieved in most cases by adding buoyancy in the form of closed cell foam floats but also by getting the centre of gravity as low as possible. This will result in stability.

Being lighter means less wrist strain and, with the added bulk/

volume of the float arms, you are pushing something much larger/bulkier through the water which has a dampening effect on any movements. With stills it also means you can hold the system much steadier so should be able to get away with slower shutter speeds.

If your system is quite heavy underwater I recommend you try buoyancy floats as I think they will make a big difference.

I learned all this from watching and diving with the late great Peter Scoones whose video housings were perfectly trimmed and balanced. I remember watching some footage he had shot that day and I remarked how good and smooth it looked. "Ah", he said, "I'd forgotten the camera was still rolling then". Such was the balance and buoyancy that even his unintentional footage was good.

4k frenzy

People are funny, aren't they? Well, not funny exactly but more weird.

Take 4k video, for example. You'd think video has just been invented and that prior to 4k the moving image was not worth considering.

Now everyone is leaping into 4k and even the top GoPros can shoot it but my suspicion is that there will only be a few who stick with it and produce watchable end products. There is so much more to do with video from the story idea, actually shooting the right footage to tell that story and then editing it and adding sound or narration.

With stills your work is mostly over when you press the shutter but with video your work has only just begun.

Parting Shot

Eagle eyed readers will notice that this issue's Parting Shot is not only written by me but is also not really the 'story within a story' that the format is designed to encourage.

Those readers who will accuse me of giving myself priority over other contributors would actually be quite wrong for this is only the second time in UwP's 82 issue history that there have been no Parting Shots submitted.

So if you have an interesting shot which has a 'story with a story', UwP would love to hear from you and you could be the next Parting Shot.

Peter Rowlands
peter@uwpmag.com

www.uwpmag.com

News, Travel & Events

10th DEEP Indonesia Photo Competition hosted by DivePhotoGuide and Wetpixel

The prestigious DEEP Indonesia International Underwater Photo Competition is part of a unique series hosted by DivePhotoGuide & Wetpixel, in association with DEEP Indonesia, Indonesia's first-ever diving, adventure travel and extreme sports expo.

Photographers will compete in six themed categories to win over \$40,000 in prizes, including underwater photo equipment and premium dive travel packages to some of the top photo destinations in the world.

The DEEP Indonesia competition is part of a unique series, that together with the Our World Underwater competition, has a prize pool of over \$90,000. The prestige of these contests means that winners also achieve the glory of being named some of the world's best underwater photographers. Esteemed judges include leading professional underwater photographers and

www.uwpmag.com



magazine editors from around the world.

Deadline for submissions
February 27th, 2015

Winners will be announced online, published by our media partners worldwide and exhibited during the DEEP Indonesia Expo.

The fee to enter is \$10 per image. As with all UnderwaterCompetition.com events, 15% of entry proceeds will be donated to marine conservation efforts.

www.underwatercompetition.com

World Shootout 2015

The World Shootout 2015 has announced that it will be accepting entries from 1 January 2015. The contest will accept underwater images taken anywhere in the world between 1 January and 1 November 2015 and offers over \$70,000 worth of prizes. The winners will be announced at the BOOT Show, Dusseldorf in January 2016.

Submit your best underwater images, taken in any destination around the world, and win some of the most valuable prizes awarded to underwater photographers, including a



\$3,000 check for the 1st prize!
Early Bird Registration, carried out from January 1st to August 30th, entitles the participant to submit a free additional set of images in each category the participant has registered to.

www.worldshootout.org

Swim with Whale Sharks
July 13 - 18 & July 18 - 23 2015
4 days on private charter
Isla Mujeres, Mexico

Swim with Wild Dolphins
June 20 - 26, 2015
6 days on a Liveaboard in Bahamas

www.GregorySweeney.com



A CCR experience without equal

At Wakatobi, rebreather divers are not just accommodated, they are welcomed by a staff that understands the special requirements of the equipment, and in some cases, are CCR divers themselves. A supply of oxygen, diluent, and bail-out tanks are available on site, along with ample stocks of sorb with oxygen fills to 206 bar, with helium available by advanced request.

Rebreather groups may be provided with dedicated boats to accommodate their extended profiles. Equally attractive as the support system is Wakatobi's marine environment itself, which offers profiles that are ideally suited to rebreather diving, along with a wide range of marine subjects that become even more accessible to those who dive silently.

Bring your rebreather and experience Wakatobi today. Learn more at www.wakatobi.com or email office@wakatobi.com.



"Overall, it would be hard to imagine a more perfect environment. You don't have to dive a rebreather to experience all the wonderful attractions of Wakatobi, but having these systems can add yet another layer to your enjoyment of this magnificent ecosystem."

Craig Willemsen, owner, Silent World Diving



wakatobi

www.wakatobi.com

51st Wildlife Photographer of the Year Competition

Open to young, amateur and professional photographers worldwide, the 51st Wildlife Photographer of the Year Competition launches for entries on Monday 5 January 2015 for eight weeks.

Critiquing the many tens of thousands of submissions to find the winning 101 will be an international jury of experts including National Geographic Senior Editor Kathy Moran, master of nature photographer, Tom Mangelsen, French aerial photographer, Thierry Vezon, and underwater photographer, Dr Alex Mustard.

Wildlife Photographer of the Year (WPY) has remained at the forefront of contemporary photography, championing the ethics, while also recognising and awarding artistic composition, narrative form, and technical excellence.

WPY 2015 judge, Dr Alexander Mustard, says: 'Like all judges I'm hoping and expecting to see amazing images, the likes of which I've not seen before. My best advice for



impressing the panel is to make sure your basics are exemplary and then dare to be different.'

There are two special awards TIMElapse calls on adult entrants to submit up to three sequences each lasting between 45 to 90 seconds, which tell a story or reveal something unique from the natural world, be it behaviour or an event; and WILD-I seeks natural world stories caught on mobile devices from young citizen reporters.

By taking part, photographers get the chance to win a trip to London to take centre stage at the 51st Wildlife Photographer of the Year Awards, as well as enjoy public exposure of their image as it tours across the world in the annual exhibition.

www.wildlifephotographeroftheyear.com

www.uwpmag.com

John Collins Photography Workshop

9-16 September 2015

Marsa Shagra, Southern Egypt

John will be offering photography and video workshops at Red Sea Diving Safari's Marsa Shagra. For this 5-day workshop, John plans to offer a combination of photo and video instruction. This is suitable to a wide variety of divers, from those with entry-level compact cameras right through to DSLR-experienced photographers, and those starting out with GoPro action cameras.

www.onasdivers.com



WALLACEA
DIVE CRUISES

RAJA AMPAT - KOMODO - ALOR - BANDA SEA - FORGOTTEN ISLANDS - SULAWESI

www.wallacea-divecruise.com

Dive Lembeh 28 Jun - 9 July 2015

We will be taking a dive trip to unique Lembeh in North Sulawesi on 28 June to 9 July 2015.

North Sulawesi is a home to many unusual species, for example the prehistoric fish “coelacanth” The dominating volcanic landscape creates a unique backdrop for you to discover North Sulawesi, one of the world’s best yet least known dive destinations The cost of \$2210 per person includes 9 nights twin share airconditioned accommodation at Eco Divers Resort Lembeh, 3 boat day dives per day for 8 days, all meals and internet access. Price also includes air-conditioned airport transfers.



Islands and the strait between the two is a world class dive attraction.

The cost of \$3215 per person includes return Airfares Bali (Denpasar) to Alor, 1 night in Bali, 9 nights at Alor Divers Resort in a beachside bungalow (twin share), all meals, drinking water, tea, coffee, 2 boat dives per day, unlimited shore dives on Alor’s amazing house reef, tanks, weights and unlimited air refills, laundry service, airport transfers in Alor and entrance to the Alor Marine Park.

www.downunderpix.com

Gerald Rambert in Truk Lagoon S/Y Truk Siren, 2nd - 12th Sep 2015

Gerald, from Mauritius, will once again be hosting a 10-night Underwater Photography Workshop with the Siren Fleet.

Underwater photographers will delight in the range of photographic subjects both wide-angle and macro. Many of the wrecks are well within recreational limits and suitable for all divers. Whether you are a beginner or more experienced photographer you can benefit from Gerald’s instruction- or simply join a like-minded group.



www.geraldrambert.com

www.sirenfleet.com

How would you like to own the land by Hairball in Lembeh?

**For Sale :
Unique Lembeh
Coastline Land**

Lembeh in North Sulawesi in Indonesia is generally viewed as the world’s top muck diving destination. And in Lembeh, Hairball is probably the most famous dive site.

Prime plot of 27,000 m² (coconut plantation) available, with fantastic views from about 320 metres of coastline facing Lembeh Island, next to the famous Hairball and TK1 dive sites. The land has an existing quality 2-room bungalow, road (and sea) access, water and electricity (and back-up generator).

Contact Colin Marshall at Colintrmarshall@yahoo.com



*Enquiries welcome.
Prefer to sell the entire holding, but open to selling the land in lots – could easily be split into up to 5 separate pieces, all with magnificent views and sea access.*



Specialists in Underwater Photography



WORLDWIDE DIVE AND SAIL

Siren Fleet



Six Luxury Liveaboards
 Spacious cabins & Dive Deck
 Superior Service & Dive Guides



Truk • Fiji • Palau
 Indonesia • Philippines

Call the experts: +44 208 099 2230
www.sirenfleet.com
info@sirenfleet.com



home Contact Us

Dive China 2015

April 28-May 1

China.Guangzhou.Asian International Yacht City No.99
 Floating Lotus Hill Road, ShiLou Town, Panyu District,
 Guangzhou

Dive China 2015 Guangzhou, April 28 -May 1

Dive China 2015 will be held in Asia's International Yacht City, Guangzhou from April 28 -May 1. Building on the outstanding success of 2014's show, Dive China 2015 will be more promising. We are planning to have about 250 booths spread over an area to 8000 sq.m. Besides, we will organize many on-site activities like seminars, underwater photography, Try Diving, etc.

Luxury Feast, the brand show of our organizing committee, aims to build a high-class business platform by gathering Boat Show, Air and Helicopter Show, Luxury brand Show, etc, under one roof.

In 2015, Dive China will join the Luxury Feast for the first time, held together with the other related exhibitions as mentioned above. For Dive China, this will be the most important turning point.

By joining Luxury Feast, Dive China will be able to share the vigorous promotion and publication through over 500 media cooperated with the organizing committee, and the most important, share the high-quality visitors brought by the concurrently held exhibitions which is expected to be over 150,000!

www.chinadiveshow.com



ALOR DIVERS
a resort where diving is passion



DIVE RESORT
 ALOR ARCHIPELAGO
 INDONESIAN SEAS

www.alor-divers.com

Your advert could be here for just £50 and will be seen by over 10,000 underwater photographers worldwide. No other publication has such a targeted audience. For more details visit: www.uwpmag.com/?p=advertise

Ultimate Manado with Nick & Caroline Robertson-Brown 6th - 20th September 2015

The Manado Region of Sulawesi, Indonesia, is world renowned for its stunning biodiversity of marine life.

Home to creatures such as Frogfish, Pygmy Seahorses, Porcelain Crabs, Waspfish, nudibranchs and forests of coral and soft sponges, Manado has quickly become a heavenly place for underwater photography. If you love all creatures weird and wonderful, the sheer variety of subjects in this region can leave underwater photographers mesmerized.

The Ultimate Manado trip will be guided by prominent photographers Nick and Caroline Robertson-Brown of Frogfish Photography and it will encapsulate this region's highlights both above and below the water.

Nick and Caroline met whilst studying Environmental Biology at Manchester University. While Nick went on to become a teacher, Caroline got her MSc in Animal Behaviour. They have worked as dive instructors abroad and in the UK, before they focused on their passion - underwater photography. Nick and Caroline now



(Image by Frogfish Photography)

run Frogfish Photography, based in Manchester, offering tuition, commissions, equipment sales and advice and running trips all around the world. The trips are specially designed to suit underwater photographers of all levels, with workshops and practical sessions to help improve the images you will take home.

www.divequest-diving-holidays.co.uk



Boston Sea Rovers DoubleTree by Hilton Hotel Boston North Shore in Danvers MA March 6th - 8th 2015

The Boston Sea Rovers are the proud sponsors of the "Longest Continuously Running Dive Show in the World," a distinction made possible primarily due to the excellent quality of speakers that have continued to grace our stages. We take great pleasure in hosting the best educators, explorers, scientists, divers and speakers in the world. The purpose of these lectures help us to achieve our club our mission, "To educate the general public about the underwater world."

Our daytime presentations form the backbone of our show. In two days we will host over 40 speakers covering a myriad of diving and marine related topics. Each hour there are three simultaneous lectures being held on Saturday and Sunday from 9am to 5 pm. You get to choose which speaker or topic you would like to see based on your interests.



The jewel of each annual Clinic is our Saturday Evening Film Festival. The Sea Rovers take pride in the fact that we have continuously blazed the trail in the underwater world, premiering more speakers and presentations from our stages than any other show.

www.bostonsearovers.com



What does your profile pic say about you?



Waterproof housings for Canon, Nikon, Olympus, Panasonic and Sony cameras. Designed and manufactured in the USA.

Find an Authorized Dealer at ikelite.com.



Your camera... anywhere there's water.

New Products

Ikelite's TTL housing for the Nikon D750 DSLR



Ikelite proudly announces the latest addition to its DSLR Housing line, which is designed to offer one of the best performance to dollar purchases in the world. The Ikelite DSLR housing is a seamless blend of functionality, lighting integration, durability and waterproof integrity.

TTL or "Through-The-Lens" flash metering means the camera controls flash duration to properly expose an image. Built-in proprietary circuitry tells the camera that a TTL external flash is attached, allowing the camera to adjust exposure more accurately than with slave TTL strobes.

An Ikelite exclusive: exposure adjustments directly through the back of the housing put the perfect shot within reach every time. Tweak your TTL exposure or take total manual control without taking your hand off your housing. A dial control on the

back of the housing acts as a remote control for compatible Ikelite DS-series strobes. Access plus/minus exposure compensation in TTL mode, plus manual power settings in half-stop increments.

This housing includes a balanced aluminum tray with our signature quick release handles for easy attachment and removal of external lighting. An aluminum 1/4-20 threaded top mount provides an additional attachment point for lightweight accessories.

Product Number 6812.75

US Suggested Retail Price
\$1,800

www.ikelite.com

Subal housing for the Panasonic GH4



SUBAL is proud to present the first rendering images of the New SUBAL GH4 housing to be released. Austrian world's most renowned uw housing manufacturer is applying the last finishing touches to the most ergonomic housing on the market for the Panasonic Lumix GH4 camera.

The meticulously crafted GH4 housing expands the possibilities for professional photographers who demand the best performance and reliability in the most challenging environments.

With its already known design, quality construction and ergonomic handling the SUBAL GH4 adds another housing to his line. Crafted from a solid block of high-grade seawater-resistant aluminum, which is anodized and put through a chemical hardening process.

www.subal.com



ACQUAPAZZA GripBase

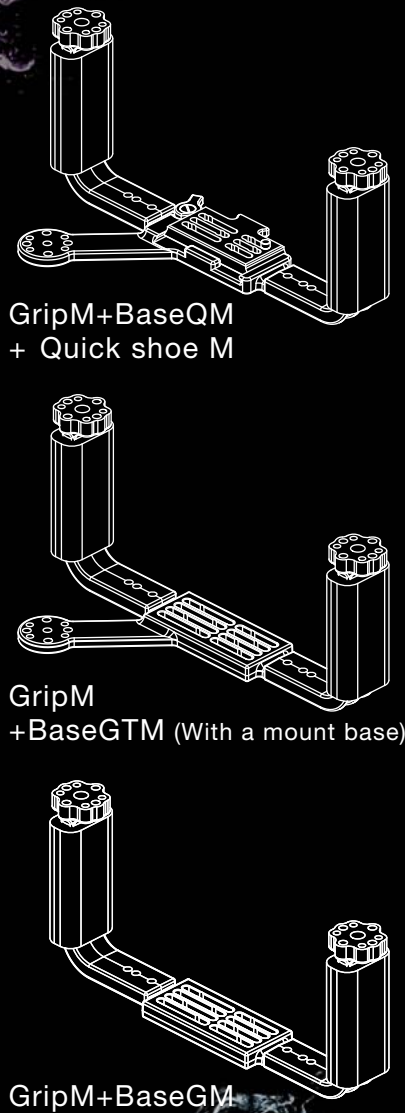

GripM+BaseQM
+ Quick shoe M

GripM
+BaseGTM (With a mount base)

GripM+BaseGM
(General purpose)

<http://acquapazza.jp/en>

Nauticam
innovation underwater



NA-7DMKII

Housing

For Canon 7D MarkII Camera



www.nauticam.cn

蓝天海

Keldan Video 8X 10,000 lumen light



Ten thousand lumens in a light is an impressive feat... especially when you pack it in a travel friendly underwater video light that is available for purchase now. It's especially impressive when that much lighting power comes in a rugged yet precise Swiss-made package that is ready to dive as deep as 200 meters.

Where other light manufacturers might use an LED (or 2) that claims it can achieve this kind of output, KELDAN delivers it; actual measured output at operating temperatures in real world conditions. This kind of obsession with accuracy is part of the reason that KELDAN lights are known as the best underwater video lights available.

Today KELDAN is proud to announce a new underwater video

light that combines high output with the ruggedness and precision that KELDAN is known for... the KELDAN Video 8X. At 10,000 actual lumens output, this is the brightest KELDAN to date. The Video 8X combines the new reflector and dome lens configuration from the popular Video 4X with a higher output led drive circuit and larger battery, resulting in a super wide 10K lumen light that packs easily for travel.

The Video 8X takes advantage of the fixed light head style (as compared to the modular Video 8M) to shunt heat effectively, allowing for the high output.

MSRP: \$2190

www.nauticamusa.com
www.keldanlights.com

ACQUAPAZZA
Coming Soon

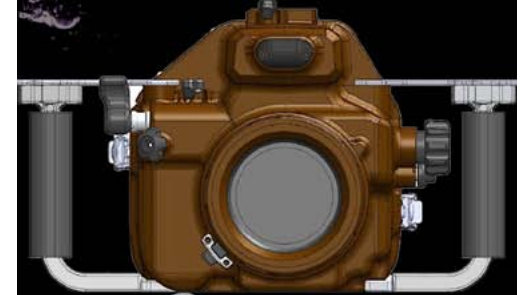

APS0-A7

Underwater Housing for the Sony ILCE-a7R/a7/a7s



<http://acquapazza.jp/en>

OPTICAL OCEAN SALES

UNDERWATER PHOTOGRAPHY PRODUCTS

Realize Your Vision

Dealers for Nauticam, Aquatica, Gates, Equinox, Seacam, Olympus, Ikelite, Fix, Zen, Athena, Sea & Sea, Light & Motion, 10Bar, Big Blue, Keldan, i-Torch/i-DAS, Seahorse, Fantasea Line, MAHA Power, and more. We dive what we sell!



LIGHTING

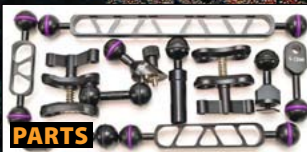

PARTS



SYSTEMS

Visit us Online at: OpticalOceanSales.com

Email: Orders@OpticalOceanSales.com / Ph: +1 206-284-1142 or 800-359-1295
1800 Westlake Avenue North, Suite 201, Seattle WA, USA 98109

Subal ND750 for Nikon D750



SUBAL announces the release of the SUBAL ND750 professional underwater housing for Nikon D750 D-SLR camera.

Designed for the world's most demanding photographers and multimedia professionals, especially those in the fields of underwater sports and nature photography as well as advanced amateur photographers.

With SUBAL's more than 40 years of expertise in housing design and manufacture, high-quality craftsmanship and ergonomic design are integral features of the new ND750. The handling and feel of SUBAL housings are unmistakable, matched only by their peerless reliability and dependability.

The ND750 housing will be available in January 2015 at an MSRP of USD 3,800 (port not included)

www.subal.com

Ikelite TTL housing for Panasonic Lumix LX100



This sophisticated installation supports all important camera functions including all three custom function buttons and front aperture dial. Rear controls are marked with laser engraved indicia which will never wear off or fade away.

The tray and handle shown are included with the base housing, providing comfortable handling and an attachment point for external lighting.

The housing port is designed to accept color filters, wide angle, and macro options for 3.9-inch diameter ports.

This housing is compatible with the WD-4 Wide Angle Dome for underwater wide angle which is sharper edge to edge than any external wet lens.

www.ikelite.com

www.uwpmag.com

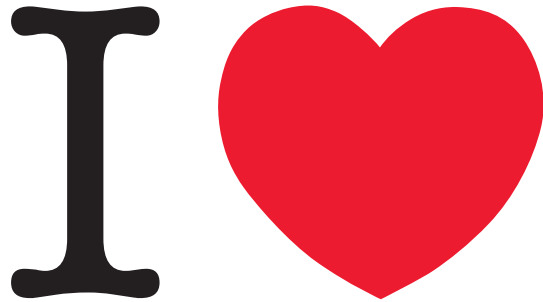

UW-PHOTOGRAPHY

Then you've come to the right place

**LIKE DIVING?
LIKE PHOTOGRAPHY?
YOU'LL LOVE US**



London's premier underwater camera store

Ocean Leisure Cameras is the one-stop central London underwater photography specialist store.

Address:
11-14 Northumberland Ave
London, WC2N 5AQ
Underground: Embankment

Contact:
Phone: 020 7930 5051
info@oceanleisurecameras.com
www.oceanleisurecameras.com

Open 7 days a week

CAMERAS

HOUSINGS

LIGHTS

LENSES

KNOWLEDGE

Acquapazza APSO-A72 Sony A7 housing

Japanese housing Acquapazza have moved forward on their development of a Sony A7 11 (ILCE-7M2) housing.

Once the Sony's lens road map had been announced, Acquapazza investigated the 28mm plus fisheye conversion lens and the 90mm Macro which will be available in 2015. A year ago since there were no such E mount lenses Acquapazza designed the housing to take A mount lenses but these were large and resulted in a large housing for a small camera.

As a result they have now developed their APSO-A72 housing to take just E mount lenses so it is both small and lightweight. The housing will take the following lenses: 28mm+fisheye, 90mm Macro, 16-35mm wide zoom and 28-70mm standard zoom. Close up lenses can be accommodated.

There are 3 x M14 screw thread sockets, 2 for strobes and one for an external monitor.

A housing will be available for the Sony HVL-F20AM strobe which will provide optically triggered TTL photography.

As with many other Acquapazza housings there are two versions of the



rear housing – the slant allows the LCD screen to be tilted or the flat can incorporate INON's 45° viewfinder as an option. There will also be an optional hand grip available.

Acquapazza will continue to produce the APSO-A7 and the APSO-A72 will be available as soon as possible.

www.acquapazza.jp/en



Scuba Symphony Malaysia
Free Shipping Worldwide* !!!!!
Scuba Gear, Strobes, Camera Housing, etc
(Almost) All brands available!
www.scubasympphony.com

*Min. order USD \$ 99.00, terms and conditions apply

Nauticam NA-D750 housing for the Nikon D750



NA-D750 is the 15th unique Nikon DSLR design from Nauticam, and evolutionary improvements inherited from this extensive heritage combined with new refinements result in the most rewarding user experience possible.

The operation of the housing in water is intuitive, comfortable, and ergonomic. Key controls are placed within easy reach of the housing handles, exactly where the underwater photographer needs them. All controls are clearly labeled, and several button and lever formats are used to allow operation by feel.

Core camera functions such as shutter release, aperture, shutter speed, live view, info, exposure compensation, depth of field preview, Fn, flash exposure compensation, focus mode, AF/M, and zoom are all located at the users fingertips. Dual thumb levers pull important functionality from the back of the

camera out to the housing handles, allowing quick access to Video Record, AF-On (for thumb activated focus), ISO, and Image Playback. The patent pending Multi Controller Pad replicates this control from the D750 Camera, allowing easy focus point selection, even on the diagonals.

Controls clustered at the right grip place key camera functions right at the users fingertips.

The rubberized handle provides an ergonomic, non-slip grip.

Nauticam's patented Port Locking Lever is simple to operate, enabling easy port changes without twisting or excessive force. A vacuum reset button inside the port mount also allows the vacuum system to be quickly reset from the port mount, when making quick lens changes.

www.nauticamusa.com

www.uwpmag.com



AMAZING MACRO OLYMPUS TOUGH TG-3



Click to View Sample
Images and Video!



BACKSCATTER
UNDERWATER VIDEO & PHOTO

USA West HQ
+1 831-645-1082

USA East
+1 603-432-1997

 Backscatter_West

 Backscatter_East

BACKSCATTER.COM/TG3

www.uwpmag.com

Keldan Video 8M Modular U/W Video Light

Announcing the Video 8M - the 2015 update to the modular underwater video lighting system widely recognized as the finest light of its kind. The Video 8M provides high output, high quality light in a modular format that allows the discerning underwater videographer to choose the right type of light needed for a particular look or set of conditions.

The Video 8M is sold in two different basic models, Video 8M FLUX and Video 8M CRI, and both include the 90°/110° dome reflector. Additional LED Modules are sold separately. The Video 8M FLUX is the high output workhorse of the family. With 9000 measured lumens at operating temperature, this light is able to add detail back to shadow areas in the brightest sunlight. The Video 8M CRI model produces 8000 lumens of broad spectrum high Color Rendition Index (CRI) light to faithfully restore colors that are missing at depth.

To the keen eye of the underwater videographer, the shape



and quality of the beam is paramount. The dome of the Video 8X allows for a 110° usable beam angle with gradual falloff. There are no hard edges to contend with even with ultra wide lenses.

The beam angle in water of the standard dome reflector when measured using the FWHM standard of 50% intensity is 90 degrees, but that doesn't accurately represent the beam pattern of this light. The usable beam angle is much wider thanks to a very even and gradual edge falloff.

www.nauticamusa.com
www.keldanlights.com



Nauticam NA-GH4 Panasonic GH4



**“Stunning 4K Video,
Compact & Affordable”**

Nauticam has crafted the ultimate housing for one of the industry's most exciting new mirrorless cameras: The Panasonic Lumix DMC-GH4. The NA-GH4 is designed with the video shooter in mind, featuring 15° angled ergonomic handles, the most user friendly control set in the business and a host of features now standard. Signature Nauticam Port Locking Lever, effortless but secure housing latch, integrated vacuum check and leak detection system. 4K is ready - are you?

www.reefphoto.com

Issue 82/17





NEW TYPE



High definition in the palm of your hand.

APSO-RX100M3

Underwater Camera Housing for SONY RX100 III



<http://acquapazza.jp/en>

Ikelite TTL Housing for the Canon EOS 7D Mark II DSLR



Ikelite proudly announces the latest addition to its DSLR Housing line, which is designed to offer one of the best performance to dollar purchases in the world. The Ikelite DSLR housing is a seamless blend of functionality, lighting integration, durability and waterproof integrity.

Special polycarbonate blends allow us to create an extremely strong yet clear and lightweight enclosure. There's no substitute for inspecting the actual o-ring seal once your housing is closed. Ikelite signature clear construction lets you see that the housing is watertight and dry before you enter the water, and provides full view of the camera while you're diving. Polycarbonate is fundamentally corrosion-resistant for easy maintenance year after year.

Like every Ikelite product, this housing is designed, built, and tested in the USA. Ikelite housings are built by hand and individually tested for fit, function and waterproof integrity. The average assembly technician is a certified scuba diver and has over 16 years of experience building Ikelite products. We back our products with over 50 years of experience and the most accessible and responsive customer service staff in the dive industry.

This housing requires the addition of a compatible lens port for waterproof operation. Lens port not included.

Product Number 6871.08 US
Suggested Retail Price \$1,800

www.ikelite.com

FROM POINT & SHOOT TO PROFESSIONAL



BACKSCATTER
UNDERWATER VIDEO & PHOTO

*We Dive, Shoot and Service Everything We Sell
Free Lifetime Tech Support!*

USA West HQ
+1 831-645-1082
S Backscatter_West

USA East
+1 603-432-1997
S Backscatter_East

BACKSCATTER.COM

Ocean critters- Clayart
Individually handcrafted, each one is unique!





Decorate & Magnet

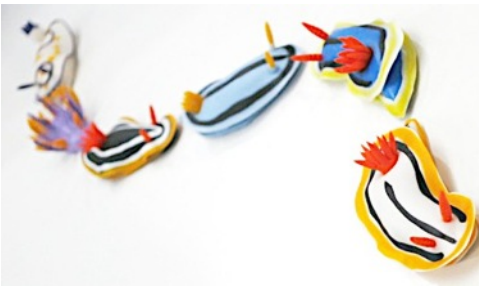

Webshop:: www.marinemagnets.net
facebook.com/marinemagnets
Email: marinemagnets@gmail.com

Nauticam NA-7DMKII Canon housing

It is clearly true that the NA-7DMKII is an improvement over the original NA-7D housing, but Nauticam has come so astonishingly far in the last 5 years that this really is not a useful comparison.

The NA-7D was an important housing for Nauticam but Nauticam SLR housings have advanced considerably. Take for example the housing latches. The NA-7D was the last Nauticam housing to use the "old school" stainless steel buckle style latches. The NA-7DMKII takes advantage of the simple yet secure locking latches that have since become famous. These latches are more secure, effortless to close, and eliminate the knuckle busting snap of the old buckles. The NA-7DMKII represents the ideal example of current Nauticam housing design.

Nauticam's patented Port Locking Lever is as simple to operate as ever, enabling easy port changes without twisting or excessive force. A vacuum reset button inside the port mount also allows the vacuum system



to be quickly reset from the port mount making quick lens changes a snap. These touches further reduce the stress of proper gear preparation and allow more time for diving.

www.nauticamusa.com

PROFESSIONAL GOPRO MACRO

FOR YOUR HERO4, HERO3+ & HERO3 CAMERA



MACROMATE MINI FLIP LENS



Click to Watch Actual Macro Video Shot with the Macromate Mini!



BACKSCATTER

UNDERWATER VIDEO & PHOTO

USA West HQ
+1 831-645-1082

USA East
+1 603-432-1997

 Backscatter_West

 Backscatter_East

BACKSCATTER.COM/GOPROMACRO

Aquatica Canon A7D Mk II housing



Building up on the initial ground breaking Aquatica A7D housing, the A7D Mk II version keep all aspect of what made this housing one of the best ever made. But with newer improved ergonomics, with a versatile port system, a rugged, yet compact design, this housing is built to bring back images in all kinds of aquatic environments.

Access to the camera controls is complete, with special attention been given to the controls of the video features, for which a smooth operation is always crucial when shooting video footage. Knobs are large sized, giving the user a better and smoother feel when working with cold water gloves, depth rated to 300ft/90m and up to 425ft/130m (free of charge) on request.

www.aquatica.ca

Aditech Mangrove VC-3L6



Aditech is pleased to announce the release of the new upgraded MANGROVE video light VC-3L6, which is smaller and lighter than the previous one.

The VC-3L6, specially designed for underwater video and photo, is supplied with a solid-State LED module array emitting a staggering 6750 lumens. Featuring two output levels, the 50W light can dim from high to medium power output level allowing you to dim lighting for a quick exposure adjustment. Sun-similar light in 16:9 illuminating with approx. 100° reflected beam angle and approx. 200 W (halogen).

www.aditech-uw.com

YS-03

Underwater Strobe

SIMPLE DS-TTL CONTROL ONLY

TURN ON AND SHOOT

IT'S AS EASY AS THAT!



PACKAGE AVAILABLE

CAMERA-HOUSING NOT INCLUDED

WWW.SEA-SEA.COM

SEA&SEA
THE UNDERWATER IMAGING COMPANY

MDX α6000



FOR SONY α6000

**THE FIRST
MIRRORLESS
'ML' HOUSING
SYSTEM FROM
SEA&SEA**

**WITH NEW
'ML' MOUNT
AND PORTS**



INON LF800-N



Inon is happy to announce the official release of the 5° super narrow LED flashlight LF800-N. The new dual use on land/underwater LF800-N produces an 800 lumen/5 degree beam with only 3 x AA batteries.

www.inon.jp

Ikelite TTL housing for Olympus OM-D E-M10

It's everything you love about an Ikelite DSLR Housing, shrunk down into a perfectly-sized package for travel. You can impress friends with your photo gear or your photos—the only housing with built-in TTL strobe exposure helps you do both!

Housing shown with MIL Port, not included. Please note that a compatible MIL Port is required for waterproof operation of this housing.

www.ikelite.com



www.aditech-uw.com
www.aditech-usa.com



Nauticam NA-RX100 III Sony RX100 III



"Simply Awesome"

With 20mp, this camera and housing package offers the complete control and image quality of an SLR system with the size and convenience of a compact system. Controls are simple, but well thought out with easy to access push buttons. Dual command dials immediately access frequently used manual settings like Manual Focus, F-Stop, and Shutter Speed. Full 1080P 50 mbps HD video performance and excellent wet lens options make for one powerful, compact package.

www.reefphoto.com

AQUALITE

eLED VIDEO LIGHTS



S 90° BEAM
500 LUMENS
100mts DEPTH RATED
3 POWER SETTINGS
BALL-ARM & SWIVEL MOUNTS INCLUDED
BATTERY AND USB CHARGER INCLUDED

PRO 100° BEAM
1200 LUMENS
150mts DEPTH RATED
4 POWER SETTINGS + S.O.S.
BALL-ARM & SWIVEL MOUNTS INCLUDED
BATTERY & MAINS-USB CHARGER INCLUDED



BOTH VIDEO LIGHTS
CAN BE USED WITH
THE OPTIONAL
UV HEAD



WWW.SEA-SEA.COM

UK Underwater
Kinetics

Light & Motion SOLA 3000



Light & Motion has announced their new SOLA 3000 Flood video light. Featuring an output of 3000 lumen and a burn time of 50 minutes at full power, the light can be charged from 80% to full power in 1.45 hours. The light will retail at \$799.00.

www.lightandmotion.com

Gates RS adapter kit

Gates Underwater Products has announced a new adapter kit for the Nikonos RS lenses.

Designed by Nikon specifically for underwater use, the Nikonos RS suite of lenses – 13mm fisheye, 28mm, 50mm macro and 20-35mm zoom – remain underwater glass par excellence. The Nikonos RS Adapter Kit fully integrates these lenses to a Gates housing, mapping focus and iris directly to the existing housing controls.

www.gates housings.com

AOI Acrylic Dome Port DLP-06 for Olympus PEN Housings

The new AOI underwater ports for the Olympus PEN series housings allow you to expand your system with the addition of new lenses. The DLP-06 dome lens port is designed for the Panasonic 8mm Fisheye Lens and allows you to get up close and personal with the underwater world. The acrylic dome is a more affordable option over glass and can be polished if scratched.



www.backscatter.com

KELDAN⁺

Advanced Lighting Technology



NEW

Keldan Video 8X
10 000 lumen
5000 kelvin
5 power settings
Rated to 200 meters
110° beam in water

For Professionals Who Know The Difference

www.keldanlights.com

Superior Firepower

Light up the unseen



SEADRAGON

Powerful new lights for dive, video or photo. Light for any camera, any dive, any adventure.

sealife-cameras.com

facebook.com/SeaLifeCameras

SeaLife

Ikelite TTL housing for the Olympus PEN E-PL7



It's everything you love about an Ikelite DSLR Housing, shrunk down into a perfectly-sized package for travel.

An interchangeable lens camera demands a housing with interchangeable lens ports. It couldn't be more simple to change ports than this system—just press the port on and tighten three thumb screws. Feel positive reinforcement that the port is secure without any complex moving parts that can jam or break in a remote location. Plus, Ikelite's signature zoom sleeves are the lightest, most affordable, and easiest to assemble out there!

www.ikelite.com

Sealux Nikon 810 housing

The CD810 housing features very small dimensions. Large O-rings, doubly sealed shafts and even quadruply sealed keys provide the highest degree of safety.

The camera does not need to be moved in order to swap memory cards. All flash units can be connected without synch leads via the fibre optics jack.



www.sealux.de

BLUEWATER PHOTO

Canon 1DX, 5D Mark III, 7D Mark II
Nikon D810, D750, D7100
Panasonic GH4, Sony A7, Oly E-M1
Sony RX-100 I II III, Canon G7X



- Fastest shipping
- Best prices
- Expert knowledge on lenses, lights & more
- Rentals & classes available
- Product videos online

Check out our Best UW Cameras of 2015

Photo trips to Philippines, Cocos, Fakarava, Solomons, Galapagos

sales@bluewaterphotostore.com - Culver City, CA +1 310-633-5052

www.uwpmag.com

Issue 82/23



NA-G7X Housing For Canon PowerShot G7X Camera



NA-LX100 Housing For Panasonic Lumix DMC-LX100 Camera

Ikelite 67mm Lens Holder



The beauty of a “wet lens” is the ability to add and remove them while underwater. This holder provides a convenient method to have your lens right at hand when you need it, and safely secured to your system when you don’t. No more stuffing your lens in a BCD pocket!

Hard anodized aluminum for strength and corrosion resistance, it attaches to any Ikelite Ball Arm Extension Mark II.

Two Lens Holders may be combined back to back to hold both your wide angle and macro lens on the same arm section. MSRP \$65

www.ikelite.com

Amphibico 5.6” HDMI, 1080p IPS LCD Monitor



Stunningly crisp high definition video can now be viewed underwater using the Amphibico 5.6” HDMI, HD monitor for above water use as well.

With an impressive 5.6” (14.2 cm) 16:9 IPS technology display, you are certain to keep your eye on what matters most and ensure that your subject is clean in focus for your video shot.

Definitely, eases the awkwardness that comes from head bobbing from eye to viewfinder and up at your subject, you do not want to take a chance missing that great shot!

www.amphibico.com

www.uwpmag.com

OpenROV



OpenROV is an open-source underwater robot. It's also a community of people who are working together to create more accessible, affordable, and awesome tools for underwater exploration.

The backbone of the project is the global community of DIY ocean explorers who are working, tinkering and improving the OpenROV design. The community ranges from professional ocean engineers to hobbyists, software developers to students. It's a welcoming community and everyone's feedback and input is valued.

The project started in a garage in Cupertino, with a few guys who wanted to explore an underwater cave. The project has evolved into a network of connected devices, exploring the oceans and lakes of the world.

You're welcome to join us! Either by building your own ROV or contributing on the forums. No prior experience necessary.

Questions or suggestions? Feel free to email us

info@openrov.com

www.uwpmag.com

SeaLife AquaPod Mini

SeaLife is introducing an addition to the incredibly popular AquaPod – the new AquaPod Mini. Similar in features to the original, the new AquaPod Mini is an extendable underwater monopod that mounts any camera with a standard tripod mount as well as GoPro cameras.

Get up close footage of dangerous or easily frightened sea creatures while remaining at a safe distance by mounting your camera to the AquaPod or AquaPod Mini. Capture both videos and stills (using the interval shooting mode on your camera) from amazing perspectives. Both AquaPods are non-corrosive and resistant to salt water, making them unique among other monopods and ideal for underwater photography.

In addition to getting up close with sea creatures, AquaPods allow divers to easily capture self-portraits - angle the camera using the adjustable knob and take the perfect underwater selfie.

Both AquaPods are non-corrosive and resistant to salt water, making them unique among other monopods and ideal for underwater photography. The anodized aluminum body, stainless steel hardware and rubberized grip give both monopods a rugged and ergonomic design.

www.sealife-cameras.com

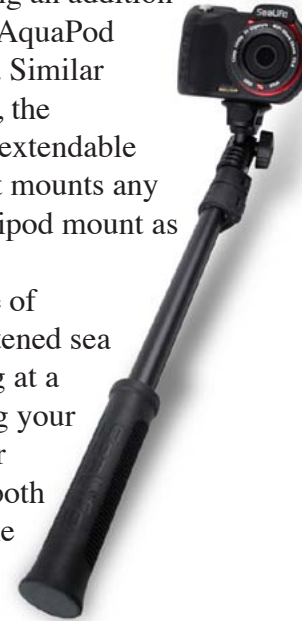

MEXICANDIVER
MAGAZINE

5th Anniversary
Underwater Digital Fiesta
Cozumel Mexico

7 Nights
All Inclusive
11 Boat Dives
Photo Workshops
April 23-30th 2015
\$1098.50

UnderwaterDigitalFiesta.com

Workshops led by professional photographer, **Phil Rudin**

A portrait of Phil Rudin, a professional photographer, smiling and wearing a light-colored shirt.

Issue 82/25





ACQUAPAZZA

NEW TYPE

Not a Digital SLR,
not a film SLR,
but with a picture quality
that exceed the two!

APSG-DPM

Underwater Camera Housing for SIGMA DP1 Merrill
DP2 Merrill
DP3 Merrill



<http://acquapazza.jp/en>



Ikelite TTL in select Aquatica housings

Ikelite and Aquatica will be partnering to make Ikelite's signature internal TTL circuitry available in Aquatica's distinguished line of housings.

Consistent exposure is the hallmark of Ikelite TTL technology. Integration directly into the housing gives the photographer total creative lighting control, with the opportunity to access both over/under exposure compensation and manual exposure settings through a single easy-to-reach control.

The visionary design of the Ikelite TTL circuitry takes its power source directly from the strobes, eliminating the unreliability of small batteries commonly used in TTL converters.

The Aquatica A7D Mk II housing for the Canon EOS 7D Mark II DSLR, to be introduced in early 2015, will be the cornerstone of this new and exciting collaboration.

This exciting partnership

provides an unprecedented access for the consumer to better photos through the most sophisticated underwater TTL exposure available!

www.aquatica.ca
www.ikelite.com

FANTASEA line
FRX100 III Housing for Sony RX100 III

The world's best compact camera has just met its match

fantasea.com | sonydiver.com



Nauticam A5000 Sony A5000



"Small & Versatile"

The Sony A5000 is blurring the lines between compact camera and DSLR with its 20mp APS-C sensor and selection of lenses allowing your pick of the right lens for the job. The 16-50mm power zoom kit lens is easily and comfortably controlled in the Nauticam A5000 housing, offering a user experience familiar to compact users, but elevating image quality to that of a DSLR system twice its size. So feel free to shoot it like a compact, but when you are ready, it can do so much more.

www.reefphoto.com

Sea & Sea YS-03 Strobe and lighting system



The new YS-03 Strobe is a simple to use, DS-TTL only strobe that has been designed primarily for new underwater photographers using compact camera sets but can be used by anyone. The only control is a rotary power switch on the rear and by simply turning it on (and positioning the strobe), the user can take beautiful underwater images. The strobe is compatible with any camera with pre-flash that also has a TTL Flash Exposure function, regardless of make.

The Lighting System includes the YS-03 Strobe Head, a Fibre-Optic Cable II M/2 plus a Flexi-Arm and Tray; all you need to add lighting to a compact underwater housing.



www.sea-sea.net

www.uwpmag.com

Bite Back Calendar

Thirteen of the world's finest underwater photographers have been united in support of Bite-Back and its goal to make Britain the first country in the world to ban shark fin soup, each donating a stunning image that features in a limited edition 2015 fundraising calendar.

Among the images is a shot of a blue shark that won Alex Mustard the coast and marine category award in the 2014 British Wildlife Photographer of the Year. Other images by international photographers Adriana Basques, Amanda Cotton, Carlos Villoch, Chris Fallows, Christian Vizl, Doug Perrine, Ellen Cuylaerts, Imran Ahmad and Lia Barrett include sharks, whales, crocodile, stingrays and manta rays.

The 2015 calendar is the eight edition of the highly popular production and it presents a beautiful reminder of the marine life at risk from overfishing, pollution and rises in ocean temperatures.

Campaign director at Bite-Back, Graham Buckingham, said: "It's very exciting to have the support and friendship of so many talented photographers. Their stunning images are a window on the beautiful yet



fragile underwater world."

Sales of the calendar are a financial lifeline for the small charity and all profits will help fund its 'Hacked Off!' campaign to eliminate shark fin soup in British restaurants.

The A4 calendar makes an ideal gift for a shark fan, scuba diver or wildlife enthusiast. It costs just £8.99 and can be shipped anywhere in the world.

www.bite-back.com

Issue 82/27



Dive Cozumel Guide

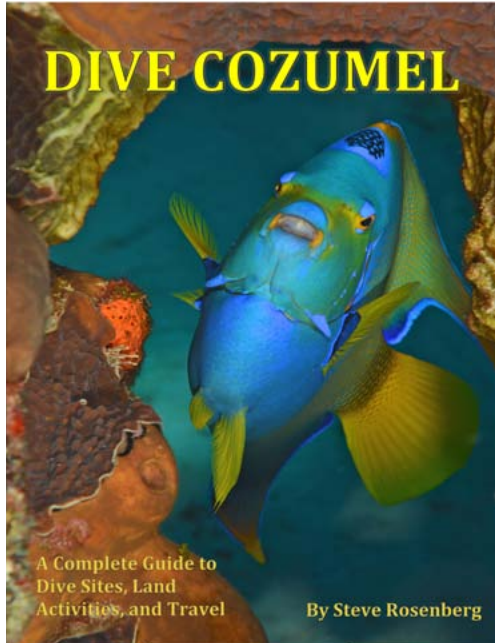

Dive Cozumel is the latest interactive eBook from well known, award-winning photographer and author Steve Rosenberg.

This eBook contains the latest information on dive sites, marine life, above-water activities, travel, accommodation, shopping, touring, island history and much more.

With over 250 high-quality color photographs, Dive Cozumel is perfect for anyone planning a trip and for those who have already visited this beautiful destination.

You can purchase the book from iBooks, Google Play or Kindle. Price \$8.95.

www.rosenbergebooks.com

Underwater Photography by Tobias Friedrich

In this book, award-winning photographer Tobias Friedrich teaches us how to create stunning underwater images, covering everything from the equipment needed, to creating powerful compositions, to processing the final image. He uses case studies to show how his own images were created, and provides detailed explanations for specific techniques that can be applied to your very next dive.

The text is supported by images from some of the most beautiful diving areas on Earth. Also included are countless tips and tricks for the beginner and intermediate photographer.

An added bonus is the 22-page Guest Gallery featuring images by some of today's most recognized names in underwater photography, including Ernie Brooks, Alex Mustard, Richard Salas, Imran Ahmad, and Eric Cheng.

www.rockynook.com/shop/photography/underwater-photography

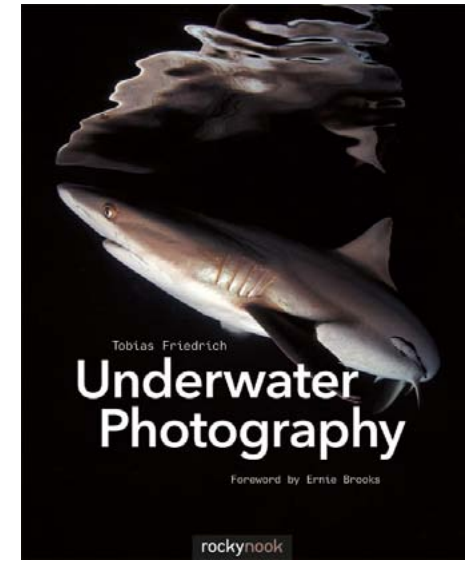

Eilat Red Sea Shoot Out book

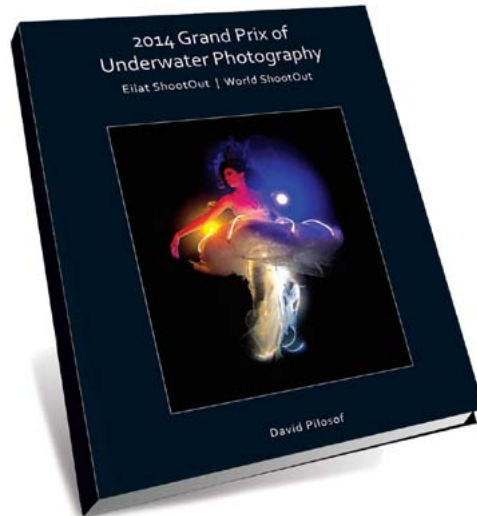

The spectacular images submitted by Eilat Red Sea & World Shoot-Out 2014 nominees and winners were all gathered together into one album.

The result is a 182-page breathtaking journey, introducing some of the best and most creative underwater images ever taken.

It's the perfect gift and a must-have for any underwater photographer, diver, fan of the sea or fan of art.

Regular price: 39 Euro

Special intro offer: 25 Euro

www.eilatredsea.com/?CategoryID=357&ArticleID=349

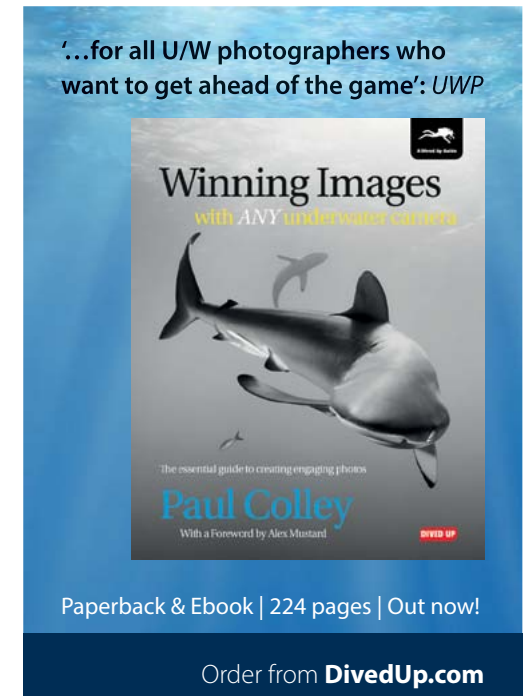

JA Universe Calendar

Jeremy & Amanda's 2015 "Diving Dreams" calendars are now available to order at a cost of £9.00 (including Post & Packing within the UK). For orders outside of the UK, please enquire and we will provide a costing including postage & packing.

Jeremy said, "The Diving Dreams 2015 Calendar features a variety of images from destinations

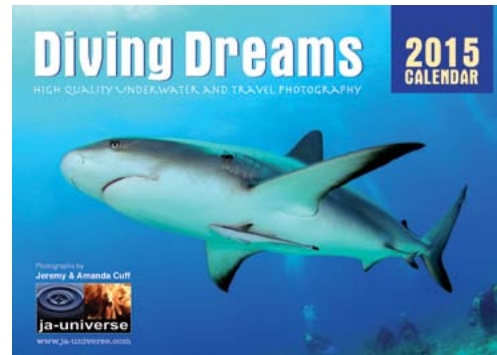

such as Galapagos, the Turks & Caicos Islands, the Cayman Islands and the Maldives."

www.ja-universe.com/calendars.htm

Underwater Dogs Calendar

Feast your eyes on the hilarious expressions of these Underwater Dogs! The calendar features a series of underwater photographs taken by Seth Casteel of Pugs, Terriers, Labradors and more. You're sure to be amused through 2015!

www.calendarclub.co.uk

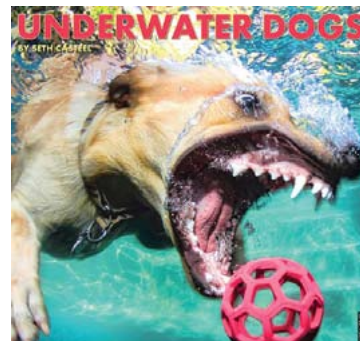

Jens Tröger Calendar

It's been two years since my 2013 calendar "Nudibranchs of the Pacific Northwest," and I've been busy gathering new photos ever since. And so, today I'm happy to share my new 2015 calendar which showcases all sorts of critters we can find in the coastal waters of the American Westcoast, from Southern California to Alaska.

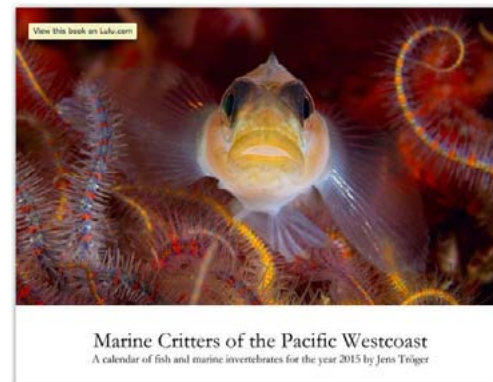

www.savage.light-speed.de/marine-critters-calendar-2015.html

WORKSHOPS

BALI
Oct 11-18

INDONESIA

PHOTO
+
VIDEO

BLUE HERON
BRIDGE

PALM BEACH

PHOTO
/
INTENSIVE

LIGHTROOM™

FT. LAUDERDALE

WORKFLOW
/
PROCESSING



www.reefphoto.com
877.453.8927

An interview with Edward Lai

by Peter Rowlands

Edward, thanks for taking time out at this busy DEMA show to let me interview you on this the 7th DEMA since you first exhibited.

At that show in 2008 you had a single product on display - a manual white balance port for various housings. What was the response at the show and did you envisage or have plans on how far you and your Company would come in just 6 years?

Amazingly the response was better than we anticipated. We met many knowledgeable people from the industry who were willing to share their insights. We were excited to be interviewed by Eric Cheng and got reported on Wetpixel - quite encouraged as a newcomer. In those 4 days we were able to receive valuable opinion and suggestions.

To be honest, by that time we didn't have a concrete plan of our future yet. I gained a lot of information and inspiration being able to communicate with so many people in one place. On the way travelling back to Hong Kong I felt I already had some nice ideas. At the next DEMA we were able to showcase our D90, D300, D700 housings, a totally

redesigned and workable version of the white balance port, and an 180 degrees viewfinder.

Timing couldn't have been worse when we started Nauticam. 2008/2009 were perhaps the worst years in history being hit severely by the Financial Tsunami. We had to close down another mold making business unit to stop losing money, and consolidated the factory for sole development of Nauticam products. We frankly didn't know how far we could go other than working hard to remain surviving. We exhausted all means of financial resources while developing new products and patiently waited for the brand to mature.

Looking back, it was perhaps this pressure that kept us alert and concentrated at all times and saved us from making terrible mistakes along our growth path. Jacqueline told many people that she had never seen her father worked so hard and under such stress.

I am assuming that you were already a keen underwater photographer and presumably like all entrepreneurs you looked at existing products and thought you could improve them?



Founder of Nauticam, Edward Lai, at DEMA 2014

Nauticam's first product in 2008 - the innovative manual white balance port which went on to win the coveted reddot design award in 2012





I was actually not that keen on diving before Nauticam was founded. I only went for 1 or 2 diving trips per year, and started photography with an Olympus 4040 in 2002 taking quite normal quality pictures with a torch. After seeing some very nice pictures of my dive buddy using a film SLR, I decided to be more serious and bought a Nikon D2X camera and housing in 2005, and was very frustrated by the problems I encountered for the money I spent. First of all, not all controls of the housing worked, and it was such a pain to install the camera, lens and gears into the housing having to align all these simultaneously. And secondly, to my surprise, TTL was not available for underwater photography even for such an advanced camera.

As a mechanic, I had been constantly changing things and improving here and there in my system. I bought two Nikon SB-800 flashes and made them work in TTL mode underwater. Later on I changed to Nikon D300 and bought a housing with optical bulkheads, and used two Nikon SB-200 flashes via commander mode from the camera. And then I changed to Inon Z-240 utilizing the S-TTL function



of the strobes. My buddy always commented I was just 'playing' with my set up rather than concentrating on real photography.

I slowly picked up more interest in u/w photography seeing small improvements that I achieved through my own modifications. Taking pictures became easier to me with TTL and gradually I got pictures that I was not ashamed to show, and all of a sudden I found joy in diving.

I had personally purchased equipment from 4-5 different manufacturers hopefully to find one that was built to my taste and expectation. Obviously this was very subjective and at times I thought I might have to build something myself in order to get what I wanted.

Prior to Nauticam what was your primary line of business and skill set?

Between 1991 and 2005 I was involved in high precision mold making utilizing the most advanced cad-cam software and computerized machinery. We built molds for many multi-national mobile phone,

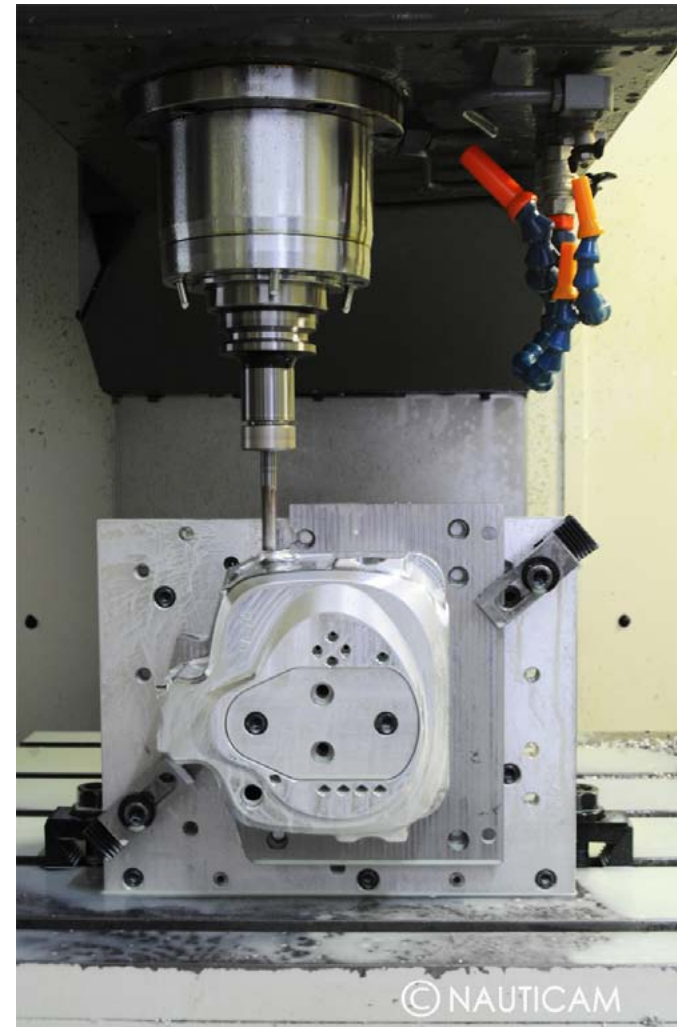

health care and electronic product manufacturers. An interesting aspect of being in this business is that we got to see many new products before they were launched, and chances to interact with product designers.

In 2000 we helped Nokia refine the design of the 5210 submersible phone and was awarded the order to build all the molds they needed for this product. Our team of 5 technicians stationed



2 weeks in Finland to ensure a smooth start up there. Some other significant projects included a rugged splash proof casing for Compaq ipaq, and rubberized shaver parts for Gillette. Interestingly all these involved waterproofing functions.

At what point did you decide to ‘go for it’ and how did you come up with such a great business name in an already saturated market?

Around 10 years ago a Finnish company who was then the biggest worldwide mobile phone plastic parts manufacturer offered to acquire my mold shop at a very attractive price. Prior to mold making I ran a custom molding business and its similarity to mold making was that they both built things to our customers’ product design. With these financial recourses we could finally chose to build something we design, enjoy to build, and with our own brand name.

These days it is so difficult to own a “.com” company. In the previous businesses we failed a few times registering our own .com domain name with our company name. Having these experiences



I did it the other way around. We spent some time on internet to try to find a ready registered company with a .com domain name, and bought it.

In the early days I imagine you were doing a lot of the work yourself but that as the demand for your products increased you had to employ staff to step up production. Was it easy to find suitably qualified employees to work with such specialised products?

I must say that I have been very fortunate having changed to building underwater photographic products. Shortly after we departed from mold making business the mobile phone industry underwent a major revolution in functionality and form. From not-so-long ago it changed from a phone with plastic casing and a lot of buttons to a mini computer in a metal frame with no button. Hence an extreme substantial drop in the use of plastic parts. The Finnish company who acquired us couldn’t survive this impact and had to be sold to a Taiwanese company which was much smaller.

We were able to get back a small team of

experienced mold designers from this change, and slowly trained them for designing our new range of products. They became an important seed team into which we could gradually add new members. It is important that we share our experience of diving and underwater photo taking with them so that they know what our customers are expecting from our products.

Your choice of housing materials has followed the traditional route of machining solid blocks of aluminium with plastic and stainless steel controls. Did you consider alternative materials such as composites or polycarbonates? Also do you see 3d printing becoming the future?

We did research other alternative materials, but so far none of these can be put into mass production in a way as economical and efficient as machining from solid blocks of aluminum. Certainly we will keep researching in this area.

On the other hand, we can see that 3D printing can be used for producing certain small parts such as a zoom gear or an internal part. But mechanical strength and dimension stability has yet to be improved until it can be applied to waterproof and constructional parts. We will keep watching the development in this field.

What criteria makes you decide to make a housing for a new camera? Presumably the Nikon and Canon SLRs are priority but do you ever get so impressed with a camera that you want your own housing for it or is it always a business based decision?

I do consider to be successful in this business you need to love photography, and the technologies



Large format Phase One 645 housing

around it. I can readily name several projects that we spent time and resources working on them regardless of the rather small user base. For example we have two housings built for the medium format cameras, quite likely a third one. I believe there is a significance for a larger format camera to be remain in the market because of their stunning file quality. We also have a housing for the Fujifilm X-T1. Again, I have great respect for Fuji and their sensor is so superior in design philosophy.

I think it's fair to say that you embraced the potential of the 4/3rds market well before most other independent manufacturers. What was it about this format that so impressed you?

Almost as a hobby I read a lot about camera/lens rumors/announcements/forums/reviews/reports. There was a lot of discussion about 4/3 sensor quality in the early days of the format, and people were waiting to see if the sensor technology would advance to a certain point of time that the



Olympus EM10 4/3rds housing

file quality from this smaller format could become acceptable. I remember in 2012 I visited the CP+ show in Tokyo and Olympus showed several very large prints from then the new OM-D EM-5 that answered this query. They were so good that you could easily believe the prints were produced by full frame cameras. Since then I very firmly believe that the m4/3 format will become an important sector of the camera industry. The much smaller sized yet optically uncompromised lenses for this format are another key success factor for the format as the ports can also be smaller and travel friendly.

Ergonomics are a strong feature on your housings. What are your thoughts and main priorities for good ergonomics?

When we are driving a car we never have to look for the shift stick, the clutch, the brake and gas pedals etc. I want to design housings that people can use them without having to find or think about the controls. They should be right there when you



need it, at the right places, within easy reach, and provide you with the tactile feel that resembles the most well built German cameras.

We want to build the culture within our company that the team thinks of good ergonomics as a must for our products, and keep identifying areas for further improvement.

Following on from that do you personally field test each prototype housing?

I still try as much as I can to field test every new housing and major products. I actually enjoy doing that a lot. But for the last year I have spent a lot of time in optical design and have had to skip a few. Luckily Jacqueline, Phoebe and Thomas can do some tests for me, and sometimes our distributor in USA and UK also help in testing new products.

Last year saw the very successful launch of your SMC close up lenses. Without giving away any secrets do you have plans to increase your optics range?

Optics is a very essential part of photography



Nauticam SMC close up lens

and I believe there is still a lot to be developed for underwater solutions. For almost two years I have been rather obsessed with the historical development of optics in order to understand what it takes to design good lenses. It is like a black art even though today we have the help of modern computerized optimization software. It still takes a lot of knowledge of the designer to decide whether to add a lens, or replace it, or remove it, or combine two lenses to a doublet etc. An acceptable end product is always a fine compromise of cost, size, weight, manufacturability and optical performance.

I do hope that our optics range will one day become a significant business sector of the company.



Nauticam's latest flagship housing - the NA-7DMK11 for the Canon EOS 7DMk11

You have been consistently ahead of the competition when it comes to getting your product to the market so soon. Would you be willing to shed some light on how you achieve this?

Back in the days when we were in the mold making business our multi-national customers had such ever unfulfillable demands that we should build highly-complex multi-cavity fully hardened molds in unbelievably short lead times. As such, we have developed a team with

the flexibility and efficiency to cater for multi-part products with short product life cycles. We are very fortunate that these manufacturing processes proved to be easily adaptable for housing manufacturing.

Finally do you have a vision of where the underwater photographic market will be in 5 years from now and what part do you hope that Nauticam will be playing?

Judging from the rapid changes

we saw in the last 5 years it is so difficult to predict the next 5. The rather young and immature digital camera industry is carrying out all kinds of experimental design concepts in order to find out which format/size/form factor/viewfinder will eventually attract the most customers, and so is Nauticam. I hope we can produce the right equipment to work well with whatever the future cameras are going to be. They should be so well made that customers can easily take good pictures/videos without hassle.

The upcoming popularity of 4K/5K TV/monitor may gradually push the boundary of quality pictures/videos. With these new high resolution displays probably even just showing a picture on the internet demands higher quality. And with the fast growing bandwidth it isn't a dream anymore that one day we will be streaming high quality 4K video at home. I think the market needs better underwater optical solutions, and hopefully Nauticam can fulfill part of this.

Thank you, Edward, for such detailed and inciteful responses.

Peter Rowlands
peter@uwpmag.com

www.nauticam.com

www.uwpmag.com

ULTRALIGHT

CONTROL SYSTEMS



We manufacture trays for your digital camera & video housings and arms to add a strobe or light.



18 years in business.
100% customer satisfaction
guaranteed.

Special
GoPro
mounts

The original arms with the O-ring in the ball.

ULTRALIGHT CONTROL SYSTEMS SELLS THE ONLY TRAYS, HANDLES, ARMS, CLAMPS AND ADAPTERS THAT ARE MANUFACTURED AND ASSEMBLED IN THE USA. QUALITY AND CUSTOMER SERVICE ARE OUR #1 PRIORITIES. ALL PARTS ARE MACHINED (NOT MOLDED) FROM THE HIGHEST GRADE ALUMINUM AND HARD ANODIZED. OTHER PARTS ARE STAINLESS STEEL.



Made in
the USA

www.ulcs.com

“Often copied,
never equaled”

Nikon D750 and Nauticam NA-D750

by Alex Mustard

On paper, Nikon's newest full frame SLR is most tempting. It boasts a 24MP FX sensor, which DxO's tests show just beats the new D810 for dynamic range and noise at the pixel level. It shoots at 6.5 frames per second and has autofocus that Nikon say doesn't just match the D810, but improves on it. For the videots, it can record full HD at 60p, 50p, 30p, 25p and 24p and uncompressed recording via the HDMI socket, with auto-ISO for smooth exposure compensation.

The D750 has a 100% viewfinder (the D700 is the only FX Nikon that hasn't), a new tilting, higher resolution screen and also squeezes in build-in WiFi (those last two have very limited applications underwater). And this is all wrapped up in a smaller, lighter, less expensive camera body, attractive to the travelling photographer and means smaller housings too.

Nauticam already have a housing out and with other brands sure to follow soon, I took the D750 to the Red Sea to put it through its paces, enjoying excellent encounters with oceanic whitetips and spinner dolphins and shooting classic Red Sea reef life and scenery extensively: both bright sunny coralscapes and dark atmospheric caverns.

The D750 is likely to be most tempting to existing Nikon shooters probably looking to upgrade from 12MP FX Nikons or any DX Nikons. The aim of this review is to tell you about the key features of the Nikon D750 and Nauticam NA-D750 and to discuss their performance critically, pointing out both strengths and weaknesses for underwater



use. I will also make comparisons with other current Nikon SLRs.

Nikon have pitched the D750 occupying a new niche between the D610 and D810. It is Nikon's fourth 24MP FX camera (after the D3X, D600 & D610), but the marketing bumf stresses the sensor is all-new, the autofocus is an improved mark II version of the 51-point Multi-CAM 3500 from the D810 and like the D810 and D4S, it has the new Group Area AF mode (the D610 uses the less advanced 31-point Multi-CAM 2700).

Autofocus is one of the D750's trump cards and includes the new grouped AF mode introduced with the D4S and claims improved low light performance over even the D810. The last Nikon camera I had with a moveable group of AF points was the Nikon D2X, so I am excited to see it back.

Grouped AF is useful for many common underwater scenarios. For example in wide angle shooting it is a useful mode, say when taking a

series of vertical reef scenics, as the AF group can be left in the lower third of the frame, where the foreground subject is likely to be, so ensuring precise focus for the optimum depth of field. However, I must admit that I have zero complaints about how Auto-Area AF works for these shots.

For macro shooting the grouped AF worked, but I found it slower than using single point (the fastest) or 3D tracking (the most versatile) for keeping a subject in focus. I also found it a little less accurate than either of the other two modes. Ultimately, the grouped AF did not fulfil my anticipation, but it is certainly nice to have the option and more time with the system might reveal more uses for it.

The famous coral caverns of southern Egypt were ideal for testing low light AF with both wide angle and macro subjects. Although I didn't do side by side tests, I am very familiar with the performance of my cameras in these conditions.



Alex Mustard putting the D750 and Nauticam NA-D750 through their paces in the Red Sea, photo by Gabriel Jimenez.

The D750 AF coped very well when shooting wide angle and I didn't have switch over to thumb focus at any point. It felt a little less sure-footed than my D4, but I attribute that to using a much smaller dome port on this trip. Shooting fish portraits, especially with a 2x AFS teleconverter I felt the camera struggled more than mine does, but ultimately is still performed very strongly and remains one of the finest AF systems in any camera to ever go underwater.

The image quality of the Nikon D750 is from the top drawer,

there can be zero debate about that. In terms of dynamic range, DxO measure it pipping both the D800 and D810 at ISO 100 and 200 and having a larger advantage above ISO 1000. As with all of Nikon's cameras the noise comes in gradually as the ISO clicks up. With such high resolutions the noise then disappears again when the files are downsized. The result is that the main limitation of high ISO is really on final reproduction size. As a result, I would say that there is no 4 figure ISO that is unusable, but the higher the ISO the smaller the image



Unlike previous mid-level FX Nikons, the D750 gets the full, state of the art, autofocus system, which is always valuable for underwater photographers who like shooting moving subjects, like this fangblenny. Nikon D750 and Nikon 105mm VR with Nikon 2x AFS teleconverter. Nauticam housing, Seacam strobes. 1/250th @ f/16. ISO 250

must be reproduced (I stayed below 3200 when not specifically testing ISO).

My main surprise was that there was not more of a difference between the new 24MP FX D750 and year old 24MP DX D7100. The full frame camera is clearly better than the DX, but not by as much as many would expect. The DxO results shows only a one stop advantage across the ISO range. And critically a DX shooter can definitely shoot one stop more open

than an FX shooter and produce the same corner sharpness behind any dome. In short neutralising the on-paper high ISO advantage of FX over DX in the real underwater world.

The D750 gives away 12MP to the D810, but I find 24MP a more desirable resolution than 36. Although I accept my view is biased by how much I shoot and my professional clients' requirements. I find the D800/D810 RAW files too hard-drive bloating, and while the

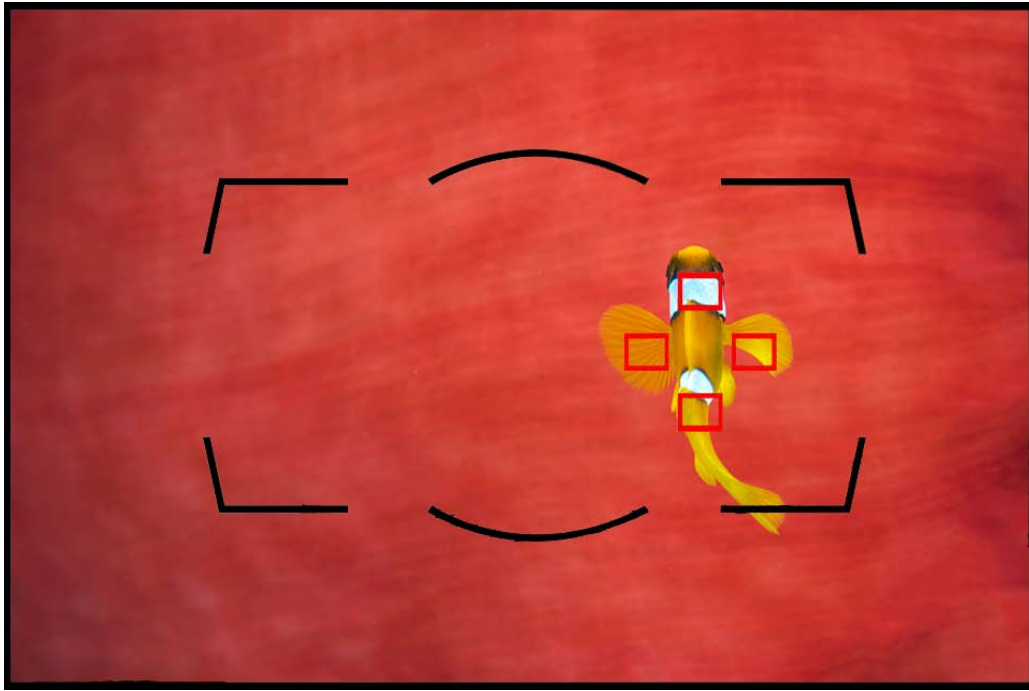

The latest generation of Nikons offer a grouped AF mode, where a cluster of sensors are active and the cluster can be moved around the frame. Nikon D750 and Nikon 105mm VR. Nauticam housing, Seacam strobes. 1/250th @ f/18. ISO 250

resolution advantage 36MP is clear on my computer screen it disappears when my images are published, as magazines can only put so many pixels on the page.

The only D750 spec that feels a slight let-down is that the flash synch maxes out at 1/250th and you can't sneak it up by a third of a stop to 1/320th, as you can on many other Nikons. I also felt that the viewfinder was a little inferior to that on the prosumer D810.

In short the camera clearly

outguns the D610 and does deliver on its promises, pushing the D810 very close in every department, at an enthusiast's price, size and weight.

Five years ago I reviewed my first Nauticam housing for the Nikon D700, concluding that it was a nice product, with room for improvement of the primary controls, but certain to see Nauticam putting a cat amongst the pigeons of the housing market. Five years on and Nauticam are a dominant force in the market, but more impressive to me is that they



Image quality is exceptional capturing detail, colour and dynamic range even at high ISOs. Nikon D750 and Sigma 15mm and Kenko 1.4x teleconverter. Nauticam housing. Seacam strobes. 1/100th @ f/14. ISO 250

have constantly worked to improve all aspects of their designs and characteristically the NA-D750, being the newest, has fresh innovations. Nauticam really listen to underwater photographers and their products are all the better for it. The primary controls on the NA-D750, which caused gripes in my original NA-D700 review, are now exemplary in the industry.

The dials for aperture and shutter speed (which are also used for scrolling through various settings)

are deeply sculpted, perfectly geared and easy to use with the lightest of touches with just a single finger. They are a pleasure to shoot with. I also really love Nauticam's multi-selector solution, which is used for moving focus points around and for navigating menus.

Some housing manufacturers aim to replicate the feeling of using the camera on land in their housing design. Nauticam aim to exceed the ergonomic solutions of the camera by placing a number of the most



An anemonefish rubs mucous from a tentacle onto freshly laid eggs to protect them from stings. The Nauticam NA-D750 has excellent primary controls to help you catch the moment. Nikon D750 and Nikon 105mm VR. Nauticam housing, Seacam strobes. 1/250th @ f/18. ISO 200

important controls for underwater shooting on levers designed to be pushed with your thumbs. On the left side of the housing there are levers for ISO and Playback, and on the right side for Video Record, Thumb Focus (AF-ON), Info and a small one for exposure compensation.

Nauticam's design philosophy is based on finding optimal ergonomic controls almost regardless of how complex this makes the designs. I completely understand the motivation behind this approach, but as a field photographer I worry about designs I feel are overly complex. Travel and time in the ocean have a way of revealing weaknesses.

Any ergonomic dislikes? The thumb lever that many underwater photographers value the most is the one that activates the button for AF-ON, allowing autofocus to be separate from the



The D750 can rattle along at an impressive 6.5 frame per second, ideal for action, like these spinner dolphins. Nikon D750 and Sigma 15mm. Nauticam housing. 1/400th @ f/6.3. ISO 1800 (Auto).

Dark caverns are a challenge for both AF and high ISO capabilities and the D750 is strong on both fronts. Nikon D750 and Sigma 15mm. Nauticam housing. Magic Filter. 1/3rd @ f/7.1. ISO 1600

shutter release. This is usually called back-button focus or thumb-focus. Nauticam have moved their shutter release lever on the NA-D750, so it is higher relative to the handle of the housing and this makes it much harder to simultaneously reach the thumb focus. Every photographer has slightly different hands, but if this feature is important to you, make sure you check it.

Nauticam also have an industry leading vacuum system on their housings. They were not the first housing manufacturer to fit vacuum seals, but, to date, theirs are the best integrated. And that gets even better with the NA-D750, which has a

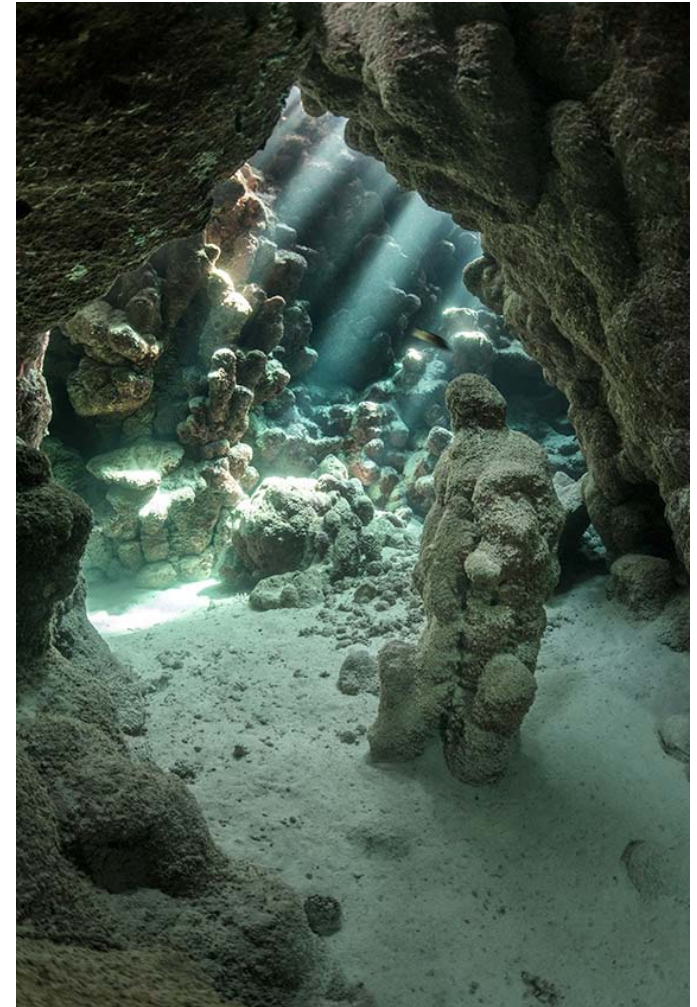

new button to allow you to reset the system when only opening the port to change lenses.

It is easy to surmise that the NA-D750 is a first class housing. It is compact, yet not too heavy in the water. It is fully featured with excellent ergonomic solutions, especially with industry leading solutions in the multi-selector and integrated vacuum system.

The Nikon D750 is a highly specified, highly capable camera, which is most definitely suited



Overall the Nikon D750 is an excellent underwater camera, highly suited to travel and capable of stunning image quality across many genres of underwater photography. Nikon D750 and Sigma 15mm. Nauticam housing. Magic Filter. 1/50th @ f/14. ISO 400

to underwater photography. It is far more of a tempting prospect in respect of the D810, than the D600 was compared with the D800. Unlike the previous generation, the cheaper option now has marginally better autofocus (and higher frame rate) meaning it is now arguably better at getting the shot.

The D750 costs considerably less (the price of a quality piece of glass) and matches the D810 in many aspects of image quality. That said

the DX format D7100 should not be ignored either, and perhaps hits the sweetest spot of all Nikon's offerings for underwater shooting. In short, Nikon users are lucky to have such options, there are no bad choices.

Alex Mustard
www.amustard.com

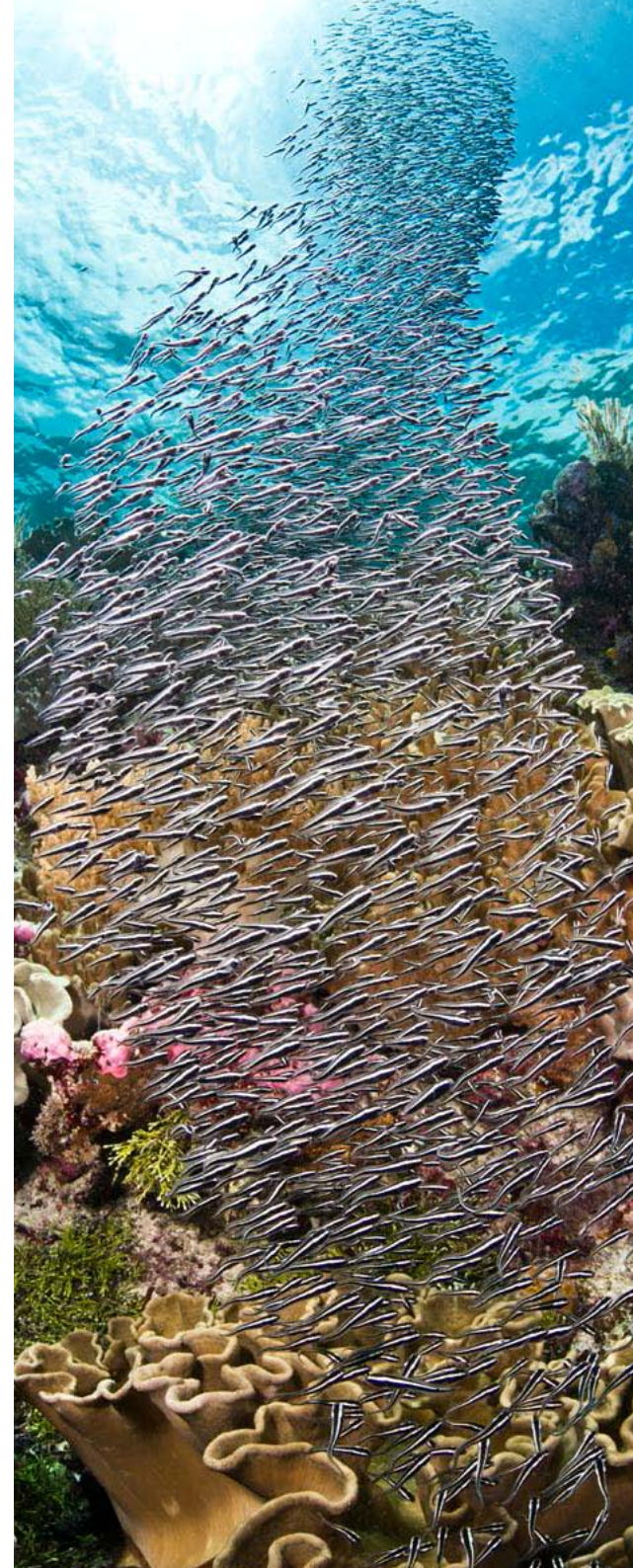

An experience without equal

"I dream of photographing underwater marine environments in wide angle where the water is clear, the light is beautiful, and the reef is healthy and teeming with marine life. Of all of the destinations I have visited around the world, Wakatobi remains the one where I was really excited on every dive by an incredible underwater perspective that made me think: 'OMG, how beautiful.'"

Warren Baverstock



www.wakatobi.com

Onderwaterhuis Flip Snoot Pro

by Dan Bolt

Snoots are nothing new to the underwater photography scene, indeed it was back in 2010 that Keri Wilk won so many plaudits for his stunning array of accurately snooted images in the Our World Underwater competition [http://www.underwatercompetition.com/Competitions/Our-World-Underwater-2010].

And so for many of us a snoot has been a useful tool to keep in our camera bags for quite some time, so I was quite intrigued to be asked to review the new Onderwaterhuis.NL Flip Snoot Pro; especially as I already own one of their existing non 'Pro' models.

What attracted me to the old Flip Snoot was exactly as the name suggests; its ability to flip away from the strobe allowing a great deal of versatility in your lighting options on a dive. My kind of diving rarely allows me to pre-plan shots or to know 100% what I will find down there so the ability to simply flip the snoot into, or out of position is a marvellous thing.

Like its older sibling, the new Pro version is build around a modular design which allows greater control

over the coverage of the light emitted by the snoot than many other models on the market. There are actually 3 different 'modes' (or 4 if you count flipping the snoot out of the way) which for ease of reference we shall call Mode 1, 2 and 3 (clever isn't it?).

Mode 1 is gives a fairly broad beam with its 67mm aperture, whereas Mode 2 steps right down to a 24mm aperture and also incorporates a diffuser to soften the light. Finally, Mode 3 uses a tiny, 10mm aperture. To have this variety of light outputs available during a dive is a fantastic tool, one which I have certainly been glad of on a few recent, low visibility dives.

The Flip Snoot Pro's modular design is based around a 3D printed base that clamps to your strobe but also incorporates components from other sources. The main body of the snoot (which gives us Mode 1) is in reality a rubber lens hood which has been firmly glued to the base. This is actually a clever move as it keeps the

Top-lit Plumose Anemones. Olympus E-PL5, 9-18mm @9mm, ISO640, f/6.3, 1/80th. Snoot Mode 1



The three parts of the Flip Snoot Pro (l-r) Mode 3, Mode 2, Mode 1

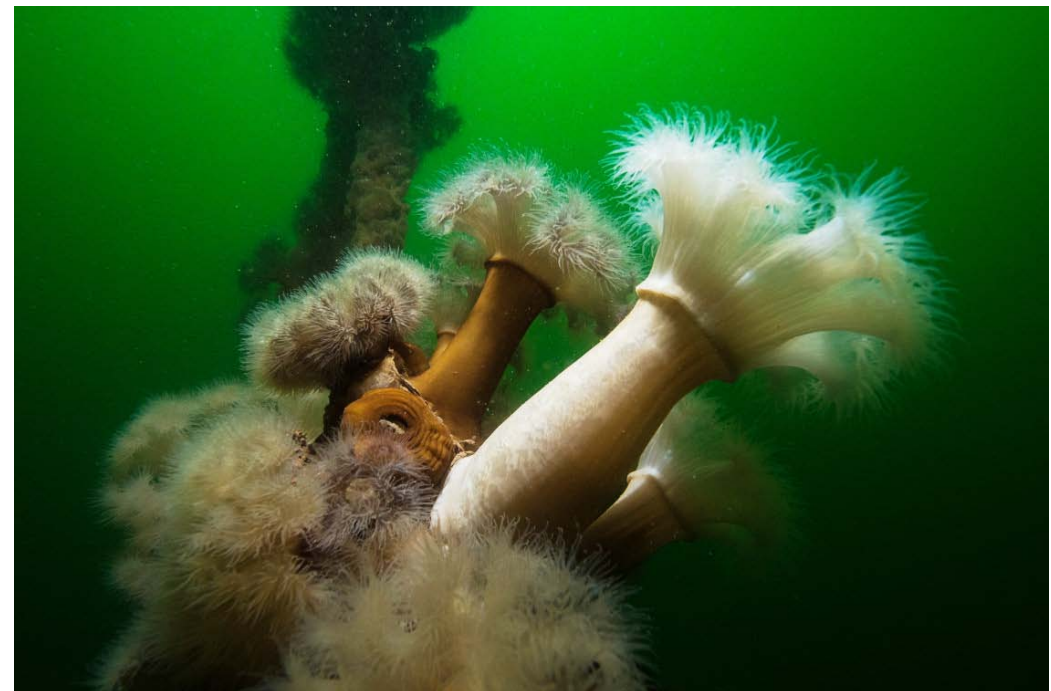



Mode 1 mounted on YS-D1



Mode 2



Mode 3



weight of the snoot down to a minimum as well as meaning that even quite a strong knock to the snoot will not cause any damage.

This rubber section has a 67mm thread at the base, into which a standard aluminium stepping ring is screwed. This stepping ring incorporates more 3D printed parts that give us Mode 2, and into which a standard Inon LE torch diffuser has been inserted. If you don't see the need for the diffuser you can easily remove it, and if you have an Inon LE torch of your own, you will probably have the red filter

too so you could actually have red snooted light. Finally, an even smaller 3D printed part can be firmly pushed onto the end of Mode 2 which simply acts to further narrow the beam of light and gives us Mode 3.

Having used the Flip Snoot Pro in both the pool and in the sea, I can honestly say it is a very versatile tool to keep mounted onto your strobe.

Close up Mode 3. Olympus E-PL5 14-42mm kit lens @ 42mm, ISO200, f/14, 1/250th, Subsee +10





Front-lit octopus. Olympus E-PL5 14-42mm kit lens @ 14mm, ISO800, f/3.5, 1/50th. Snoot in Mode 2

Back-lit octopus. Olympus E-PL5 14-42mm kit lens @ 14mm, ISO320, f/4, 1/250th. Snoot in Mode 2

Back-lit Plumose Anemones. Olympus E-PL5, 9-18mm @9mm, ISO320, f/8, 1/160th. Snoot Mode 1

In fact you could leave it in place all the time (but at the cost of not being able to use the wide-angle diffusers supplied with the YS-D1) and have a very flexible lighting tool to hand for all photographic occasions.

Looking at the new and old models side by side, you can see that the new Pro snoot is 4cm shorter with a less-gently tapering body. Obviously this has no effect on the light emitted but if, like me, you have a relatively

large housing (Olympus PT-EP10) compared to your macro port (45mm Panasonic macro) then the shorter snoot might make it more difficult to get the body of the strobe into the required position. I certainly found the old, longer model was easier to use with my setup.

The final observation about the Pro snoot regards the flexible (also touted as 'collapsible' by the manufacturers as pushed in it shortens

the unit by 3cm) rubber body while using your strobe on your housing (rather than mounted on a tripod). In the old model, the rigid design allowed for very small adjustments in the position of the light by gently tweaking the end of the snoot by a few millimetres. Unfortunately the new rubber body in the Pro snoot means that you can no longer do this, and instead have to move your strobe itself to achieve the desired position

of the light – and when we're talking about macro/super macro photography this can be frustratingly fiddly to achieve.

Despite my two (quite personal) minor issues, I very much enjoyed using the Flip Snoot Pro and it is a welcome addition to my kit collection; it's versatility underwater is a highly desirable feature for my kind of photography.

The Onderwaterhuis.NL Flip Snoot Pro is now available at www.Onderwaterhuis.NL for €129 and is available for Sea & Sea YS-D1, INON Z-240 and the Ikelite DS-161. DS51, S-2000, and other models will also be available soon.

Dan Bolt

www.underwaterpics.co.uk

www.underwaterhuis.nl



Don't settle for 2nd best



Film - No Filter
No White Balance



Digital - No Filter
Manual WB



Magic Filter
Manual WB

Digital cameras have opened up new possibilities to underwater photographers. For available light photography manual white balance is an invaluable tool for restoring colours. But when you use it without a filter you are not making the most of the technique. You're doing all the hard work without reaping the full rewards. These three photos are all taken of the same wreck in the Red Sea. The left hand image was taken on slide film, which rendered the scene completely blue. The middle image is taken with a digital SLR without a filter, using manual white balance. The white balance has brought out some of the colour of the wreck, but it has also sucked all the blue out of the water behind the wreck, making it almost grey. The right hand image is taken with the same digital camera and lens, but this time using an original Magic Filter. The filter attenuates blue light meaning that the colours of the wreck are brought out and it stands out from the background water, which is recorded as an accurate blue.

www.magic-filters.com

DeepPro GoPro H3 Housing & BigBlue VTL2500P Light

by Ron Lucas

I am no videographer but would like to produce short clips of fish, wrecks and reef sites with a view to adding them to the free BZS Bermuda Reef Life HD app for iOS and Android at some point. I know that at very least I would need a Panasonic GH3 or 4 or equivalent plus a housing and dome with an expensive wide angle lens to get professional level footage - an investment of over \$3,500 without lighting. For short clips to back up HD still images I am reluctant to spend this kind of money.

So two Christmases ago I chose the budget route and persuaded my wife Lorraine to gift me a GoPro Hero 3 Black, a LCD Touch Back, a SOLA 2000 video light and a ULCS handle and tray. I thought I was all set as I could use my existing arms and clamps. I anticipated this might be the ideal setup for days when I go diving at short notice or otherwise could not find the time or energy to set up my DSLR rig for still photography. After all one can even get still photos with the GoPro as well as video. I was on my way! I could mount the GoPro to the top of my DSLR housing for overseas trips.

Since 2012 two new generations of the GoPro with incremental improvements have been released and we are now up to the GoPro 4 which has 4K video. albeit underwater it would probably be better with a small sensor to use one of the lower HD resolutions.

I very soon found the shortcomings of the GoPro system for underwater use. These include the very light weight of the setup which greatly impacts video stability and more important for me the close up minimum distance of about 12 inches before focus is achieved which is too far on a wide angle lens camera for smaller fish photography. The lack of a zoom facility is only partially resolved by the different wide angle settings but I could live with that. Then, as has happened to a couple of friends GoPros, the plastic camera housing started a minor leak - I could not work out where but I suspect around one of the push button controls. My view is that the \$60 GoPro Scuba Housing is not suitable for sustained use at depth. Well perhaps for occasional SCUBA use and probably fine for snorkelling



GoPro Scuba Housing and DeepPro GoProHousing

and free diving. Some folks have had more success. I was able to rescue the camera thanks to desiccants absorbing most of the moisture. I purchased a replacement GoPro Scuba Housing but was afraid to use it in case it leaked and I wrote off the camera!

When the USA made DeepPro housing was announced I put my name down with the manufacturer for one of the first batch and also ordered a BigBlue Video light, both of which arrived late September. The very solid hard anodised DeepPro

6061 aluminium housing with all stainless and brass hardware has been tested to 450 feet and so is suitable for technical diving although I rarely go beyond 100 ft. Because it features a lexan dome with shade and a built in diopter, it is optically corrected for excellent underwater wide angle without degradation and with the same field of view as the GoPro POV (point of view) settings above water. These are significantly reduced underwater by the flat port of the GoPro housing which comes with

the camera. The DeepPro has proper levers instead of buttons, closeup ability to 6 inches, a built in shade for the LCD window plus a tray with 2 handles. Actually it is much easier to install the camera and close the housing with the two locking spring clips than using the mechanism on the GoPro plastic housing. For divers who do not want to use video lights a filter can be installed, preferably by DeepPro for blue or green/fresh water. The housing is slightly negative in water which is a good thing for video but if using video lights I suggest adding some flotation. I used medium foam floats on my second dive and this was a great improvement. I have been providing feedback to DeepPro on a couple of very minor aspects and these will be incorporated in future batches. They are related to the handles/tray and instructions rather than the housing itself which I have found great in use. It really just takes minutes to get the outfit ready for diving if batteries are charged and the micro SDHC card installed and formatted. When not in use I keep the main housing O ring in a sealed ziplock bag rather than leave it in the housing groove to deform. The GoPro 3, 3+ and latest 4 cameras all fit the DeepPro Housing.

Trays for future batches will incorporate a centre hole so that a tripod can be installed and



Nauticam Housing and DeepPro GoPro housing

possible tripod solutions include the GorillaPod Focus or the ULCS Tripod Clamp which I have purchased and is shown in the photo using 8 inch ball arms as legs. For those with the wherewithal it would be best to purchase a fully featured underwater tripod but I only expect to use a tripod arrangement from time to time for close up video of nudibranchs and the like. The cost of a high end underwater tripod would otherwise buy a backup GoPro camera. Anyway a full tripod unit would probably be too big for this setup. A setup button control lever has been added for the GoPro 4 although I personally feel that set up should be carried out prior to diving and placing the camera in the housing.

So far I have taken the DeepPro housing on a couple of one hour shallow shore dives and a deeper 55 foot wreck dive where it has performed admirably. Stability



Diver in Wreck, DeepPro Housing, GoPro 3 set on Medium still image, with Big Blue and Sola Video lights

in operation is a light and day improvement over the GoPro plastic housing as is closeup performance. As suggested I removed and clipped the included vinyl dome cover to my BCD once in the water before descending and replaced on surfacing to help prevent scratches to the dome. I would prefer a neoprene dome cover with a draw string as the vinyl cover comes off a little too easily. I have got some video clips of a common in the Caribbean, but rarely seen in

Bermuda, Schoolmaster Snapper and a Blue Parrotfish pooping which might be used by the educators at Bermuda Zoological Society to demonstrate that up to 40% of the sand on our beaches is created in this manner!!!! The kids will love it!! The housing built in LCD shade is quite effective. One problem I do have is the small size of the GoPro LCD screen and wonder if there is anyway this could be magnified.

A GoPro 3+ battery lasts about

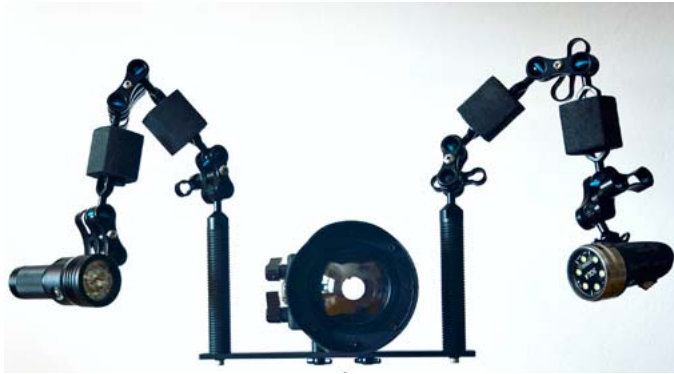

DeepPro GoPro Housing with BigBlue and Sola video lights

an hour which is not long enough for me as I usually do two or three dives in a day. I do have spare batteries but rarely risk opening housings between dives on smaller boats in open ocean. However, a solution to significantly extend the GoPro battery time is in hand at DeepPro as they are in the final stages of testing a trickle charge supplemental battery which will fit in the housing. Vivid Housings has developing a Leak Sentinel for the accessory bulkhead port so owners will be able to draw a vacuum to test the housing integrity above water and review during the dive if they wish to add this feature. Both these and other items should be available from DeepPro around when this review is published.

DeepPro install and recommend using 2 small desiccants in their housing and sell packs at nominal charge. I'm not sure they are necessary as I have seen no signs of condensation but they are a good idea in a small housing anyway.

The DeepPro housing does have four hardware mounting holes for the tray and other accessories but in my opinion it is a little too large to mount on



Forceful Tug, DeepPro housing, GoPro set on Wide. Video Frame Clip with ambient light

another camera rig. For size comparison take a look at the photos shown with the standard GoPro dive housing and a medium size DSLR housing

First impressions of the DeepPro GoPro housing are excellent and although it costs \$1230 (twelve hundred and thirty) dollars more than a replacement GoPro plastic housing the phrase "You get what you pay for" comes to mind. Don't forget when looking at cost it includes the built in dome, diopter, tray and handles. It is so much easier to carry underwater than a DSLR set up.

The instructions from DeepPro are quiet comprehensive and they offer servicing and extended warranty which is recommended every two years. I have found responses from DeepPro to all queries and suggestions to be great. The housing comes with a 2 year warranty and includes a spare body O ring. A complete set of O rings costs \$15 and a replacement dome and O ring just \$50. Check



Grey Snapper in Wreck, DeepPro Housing, GoPro 3 set on Medium still image, with BigBlue and Sola Video lights

out the details and sample videos on their website <http://deepprosystems.com>. For airline travel the whole setup including lights and chargers would easily fit into a carry on bag on most airlines.

The Bossk BigBlue VTL 2500P Li ion rechargeable 2500 lumen fully featured 120 degree wide adjustable power video and technical light is a bargain, especially when bought from DeepPro in conjunction with a housing as they offer kit prices at discount. On its own it costs \$430. The solid build and technical specification match those of the DeepPro Housing and is rated for 100m. It has 4 video light intensity levels, an alternative 10 degree spot light beam and a built in red mode for night diving so you do not scare the fish. There is an accessory Goodman glove for hands free operation, a yellow filter and a ball mount. The battery level indicator surrounds the single push button switch which takes a little time to get used to. I suspect

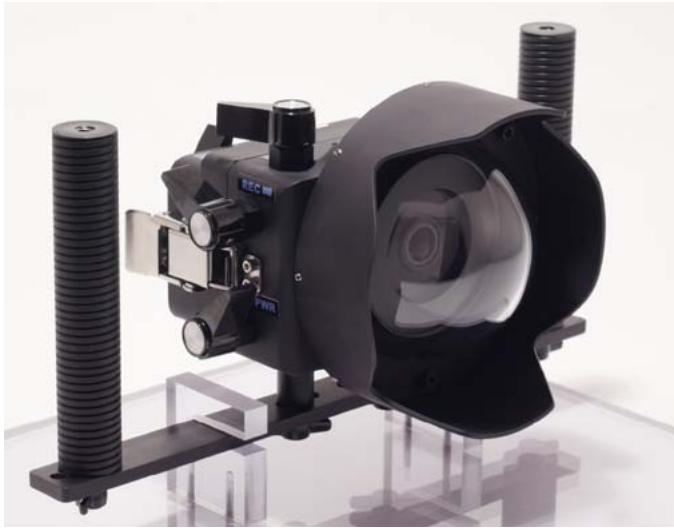

DeepPro Systems Domed GoPro Housing

with judicious use I will get 2 dives from the light as during my first dive it was only down to medium charge after leaving on for one hour at maximum intensity. The removable battery takes several hours to fully recharge in the supplied external charger but if you purchase a spare battery as I did this would be of little concern. In comparison to my 2012 model Sola 2000 video light it has many more features, is more powerful, heavier built and more versatile. However I will have to pay particular attention to the double O ring servicing each time I install a battery whereas the Sola 2000 is charged externally without removing the battery which substantially reduces the likelihood of a flood. Also at just over 461g with battery it is almost twice as heavy as the Sola 2000 which is very light. However, battery burn time is much longer. DeepPro confirm that they will liaise with Big Blue should the video light fail from other than misuse during its one year warranty period.



BigBlue VTL 2500P Li ion rechargeable

I should be pleased to report further on this housing and lighting solution to interested persons by email to ronlucasphoto@logic.bm once I have had more dives with the setup. I anticipate using it many times in 2015. Maybe one day I will be able to call myself a videographer!

Please note that I cannot comment on the long term durability of either of these products until I have had further experience with them. I paid for both items at published kit prices for personal use only and my review has not been influenced in any way by DeepPro or BigBlue.

Ron Lucas

Author of the free Bermuda Reef Life HD App for iOS and Android smartphones and devices

www.ronlucasphoto.smugmug.com



The Author in Caraquet Boiler D7100 Nauticam Housing, Inon 240 Strobes, f9 1/125

We've got you covered!

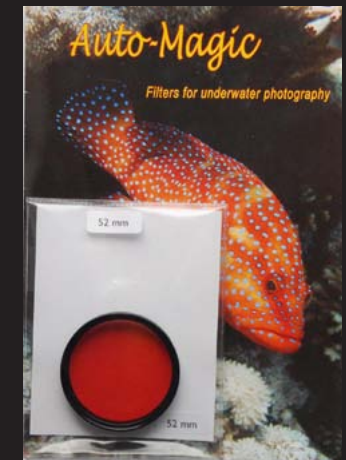
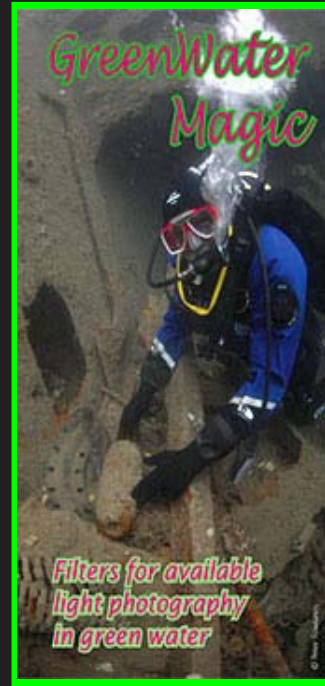

Magic filters are now available in 3 options. Original Magic for use in blue water with DSLR and compact cameras with Manual White Balance, Auto-Magic for compact cameras in automatic point and shoot mode. GreenWater Magic for use in green water with DSLR and compact cameras with Manual White Balance. Prices start at just £19.

The Auto-Magic formula is now available in a Plexiglass filter that can be added or removed underwater.

www.magic-filters.com

From Stills to Video

by Rob Duncan

I have always had an interest in shooting video, but as a still shooter, the whole process has always intimidated me. The shooting and post processing that go into making a great video seemed daunting. But with video becoming more of a relevant feature of still cameras, I thought that it might be a great time to take that leap.

I had an opportunity to travel to South Florida along with fellow Backscatter West teammates, Sean Boone and Becca Boring, to shoot under the direction of Nauticam USA's Chris Parsons. We arranged a couple days of boat diving with Pura Vida Divers, as well as three evenings of diving the Blue Heron Bridge. This meant that I would have a chance to try some wide-angle video drift diving off the boat, and be able to get some great macro video while diving at the Blue Heron Bridge.

I opted to use the new Panasonic GH4 Micro Four-thirds camera along with the Nauticam NA-GH4 housing. Lens choice was fairly easy, the Panasonic Lumix G Micro 4:3 FISHEYE 8mm for wide angle, and the Olympus 60mm macro for the close-up shooting. Here's a list of a few essentials you'll need to consider

when making the transition from stills to shooting video.

Setting Exposure

You are going to want to set your exposure before you start shooting. There is a lot of discussion on frame rate and shutter speeds. Frame rate refers to how many actual frames are being exposed per second (30p = 30 frames per second and so on). Shutter speed is how long each one of those frames is exposed (1/60th means that each frame is exposed for 1/60th of a second). For the best results, you typically want to double the shutter speed over your frame rate. So if you have your camera set to 30p frame rate, you should have your shutter speed at 1/60th of a second. Just remember like still images, if you drop your shutter speed too low you will start to get motion blur in the shot. But play around with this, you might find a combination that fits your creative eye.

As with shooting stills, setting aperture adjusts your depth of field (DOF). For shooting macro video you need as much DOF as you can so I was running at f/18 and even f/22 to maximize my DOF. With lights, this is very easy to do. For shooting wide



video where lights have less of an impact on the scene, I was shooting at f/8 or f/11 most of the time.

Once you have set your aperture for DOF, you have only two adjustments to consider, ISO and light power. Depending on the camera you

are using you may not want to run your ISO up too high, so having lights that have some adjustment in output is great. You can even adjust the exposure by moving the lights closer or further from the subject. If your lights are not powerful enough to get

a good exposure, you will have to sacrifice DOF in order to get the exposure correct.

Stability is Key

Shaky video is never good. With macro video even the slightest movement is very noticeable. This is why a tripod is not only recommended, but required in order to capture steady video. I used the XIT404 Tripod Bracket along with their Twist Clamp Tripod Legs. The bracket is a great platform for mounting pretty much any sort of housing to. The twist clamp legs are very easy to use, and can be adjusted very quickly so that you can make adjustments on the fly and get that perfect composition. To help stabilize the rig while shooting wide-angle video, I removed the tripod legs and mounted a very long strobe arm on the left side ball mount of the tripod bracket. I angled it back so that I held onto it with my left hand, and with my right hand held onto the housings handle and operated the controls. To get my rig more neutral in the water, I used the Nauticam Carbon Fiber Double Ball Float Arms.

Nail the White Balance in Camera

Unlike shooting stills, you do not have RAW files with video. Therefore you have very little leeway in making color correction adjustments in post processing. Because of this, you really have to get your white balance as close to perfect in camera. If you are very close to your subjects where the ambient light is not going to be a factor you can get away with an auto white balance. But anytime where the ambient light will be a part of your scene you must execute a manual white balance, even if you are using lights. Doing this will insure that your background color will be spot on. This means

www.uwpmag.com

that being familiar with the manual white balance process on your camera is necessary. If this is not something you are familiar with, refer to your camera's instructions, or give us a call and we can walk you through the process. In a location like the Blue Heron Bridge where you have a light colored bottom, this process is fairly easy by white balancing off the sand. You can, of course, also use the palm of your hand, and I know some people even carry a slate, or use white dive fins.

Get Creative With Your Lighting

With LED technology advancing very rapidly, there is a huge selection in video lighting that has become relatively inexpensive and easy to use. Let's face it, unless you see a behavior that nobody else has seen, it is very difficult to capture a compelling video. If you get a little creative, you can get some amazing results and set your videos apart from all the rest. Lighting is an easy way to do this. Experiment with different lighting positions so that the shadows help separate your subject from the background. I even mounted a new Fisheye FIX Neo 2000 DX SWR light on a separate tripod so that I could position it into pretty much any location around the scene. I positioned the light directly above the subject giving a spotlight effect. I even put the light down low and off to the side creating interesting shadows. This new light features a spot beam as well as a wide beam. The spot beam was great, but was not narrow enough for what I wanted to do so I improvised a snoot that I attached to the light giving me a very narrow beam of light that would allow me to light just the subject and keep the surrounding scene dark. When shooting wide angle, I used the new Keldan Luna 4X video lights. These are similar to the original Luna 4s but are

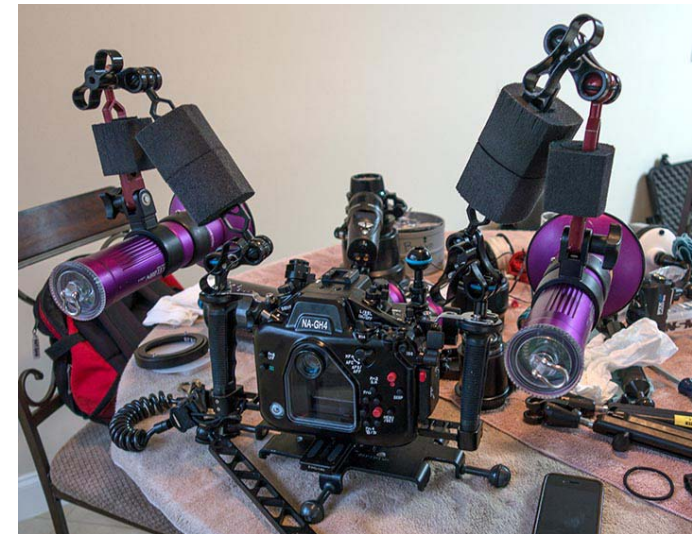

now 6000 lumens, and feature a dome port giving you a much wider even beam making them the perfect choice when shooting with the fisheye lens.

Focus Is Crucial

Just like stills, you cannot bring an out of focus video into focus in post. Make sure that your focus is “tack” sharp before you even start recording. With in-camera tools like focus peaking, even if you have bad eyesight you can tell if the subject is in focus. I personally used the manual focus feature a lot on the GH4 to really nail it. The great thing about the GH4 and the Nauticam housing is that it is very easy to switch between autofocus and manual focus with just the flick of your thumb. I would sometimes switch into autofocus so that I could get in the ballpark, but would then switch into manual focus to fine-tune it. For macro video, you really want the focus to be on the subject's eye, so make sure the eye is as sharp as possible.

Shoot More Than You Think You Need

Shooting a still image captures a brief moment

of time. With video, you are capturing a sequence of events, and a lot of the time you are capturing a behavior.

So it is always a great idea to capture as much footage as possible. Let the camera run for a while. There is no way to avoid camera shake when starting and stopping the video, so having some lead-in time, and lead-out time on the clip is a great idea. Letting the camera run for a minute or two might be enough, but if possible let it run longer. You can always cut the clip down, but there is nothing more frustrating than stopping the camera just as something cool happens. Memory cards are relatively cheap, so fill them up.

Learn Behavior

Watch how the critters move around, and react to your presence. Anticipate what they are going to do next. If you are trying to shoot a shy subject, act accordingly. Approach with care, and don't blast them with light right away. It's a good practice to set the shot up, nail your focus before you turn the lights on. This is a good way for the critter to get a little more comfortable to you being there, and might not get as spooked when you do power up the lights. Also be respectful to the critters. They are much more sensitive to light than we are, and sitting there with all those lumens of light blasting them in the eyes could

make them uncomfortable. Get your shot, and move on.

A Different Way of Looking at Your Subjects

I was a little nervous taking this leap into video. I felt that there was so much to learn, and so much to remember. But once you have these basics down, it is actually very easy, and quite fun. Video gives you an entirely different way of looking at subjects, and opens your eyes to a whole new way of expressing yourself. I am eagerly waiting for my next opportunity to get in the water and shoot some video!

Rob Duncan

www.backscatter.com



Copyright © 2014 Christopher Parsons



Issue 82/52

ADAM HANLON

WETPIXEL



THE SOURCE

www.wetpixel.com

Storytelling

by Eric Hanauer

The mechanics of shooting video underwater is fun and relatively easy. If you are in the right place at the right time with the right equipment, you should get some usable footage. What's hard is assembling that footage to tell a story. Yet this is what separates watchable video from failure. Telling a compelling story is the most essential element in successful films.

I've judged a few video competitions. Invariably, the winners are the people who tell the best stories, not necessarily those with the most sensational footage. The entries that rank in the lower half are what we call "moving stills." These are simply clips of marine creatures organized in no obvious manner, accompanied by music that may or may not fit the imagery. Although the artistry may be there, the story isn't.

At the bottom is the cringe factor. These videos lack focus, color correction, are shot from above looking down on critters, and suffer from shaky camera syndrome. They are poorly shot, poorly organized, and so poorly presented that it's a pain to watch them all the way through. A lot of the underwater videos you'll see on

YouTube fit this description.

Consider the Audience

You aren't making a video for yourself; you are making it for the viewers. Check your ego at the door to the editing room and become the audience. In order to do that, you need to visualize the audience, put yourself in their shoes, and talk directly to them. Who are they? What is their age and gender? What do they already know about your subject, and how much needs to be explained? What is the purpose of your video? Is it education, entertainment, promoting conservation, humor, or a combination of those?

Chances are your audience will be a mixture of experienced divers, non divers, adults, and kids. You'll have to decide whom you wish to speak to, how much to explain and how much to take for granted. Don't be afraid to aim high. Some

Karen Straus shoots a Nauticam RX100 system on the Kittiwake in Grand Cayman.



things may go over some heads, but be caught by others. Excellent examples of speaking to different audiences are the animated Pixar movies. Take “Wall-E” for example. For kids it’s fun and adventure and entertainment. For adults it’s a warning about a dystopian future when the world is abandoned to trash, and obese humanity becomes helplessly dependent upon machines. The people who produced that movie visualized their audiences and spoke directly to all of them.

One method I use is role playing. As I view edited versions of my video I’ll simulate being a diver, a non diver, a marine biologist, and an experienced filmmaker, one role at each viewing. I’ll imagine what’s going through their mind as they watch the film, and what their reaction might be. Has the biologist detected a mistake in explaining animal behavior? Does the filmmaker think my transitions are amateurish? Does the non diver understand what I’m talking about? Is the diver bored with all the explanation?

Another method is to show the video to one or two trusted friends who aren’t afraid to tell you exactly what’s on their mind. I’m not looking for praise here, but honest critique of what works and what doesn’t. Watch their reaction to your film. Are they laughing at the parts you think are funny? Are their eyes wandering when you think they should be involved? The bottom line: remove yourself from the picture and think like the audience.

Filter effect

During my careers I’ve been a teacher, a writer, a photographer, and a videographer. These pursuits have a lot in common. You gather all the knowledge or images you can, sort them out,



Karen works for a low angle on a stingray in Grand Cayman

discard the junk, file most of the rest, and pass along the best of it to your students, your readers, or your viewers. If you are passing along 10 to 20% of what you know, or what you’ve shot, the result will probably be successful. If you are passing along 50% or more, you are likely to fail.

You are the filter for the audience, and the eyes of the viewer. If you are telling, or showing them nearly everything you have, you need to learn or shoot more. So research your subject. If you’ve filmed humpback whales, learn about their life cycle, their migrations, their mating and parenting behaviors, and threats to their existence. Instead of just describing what the audience is seeing, tell them the backstory that’s not on the screen.

Grab Their Attention

Start out with a bang. If you don’t get their attention in the first 15 seconds, chances are the viewers will be tuning on to something else. This is especially true online. So don’t save that sensational clip for the grand finale, because nobody

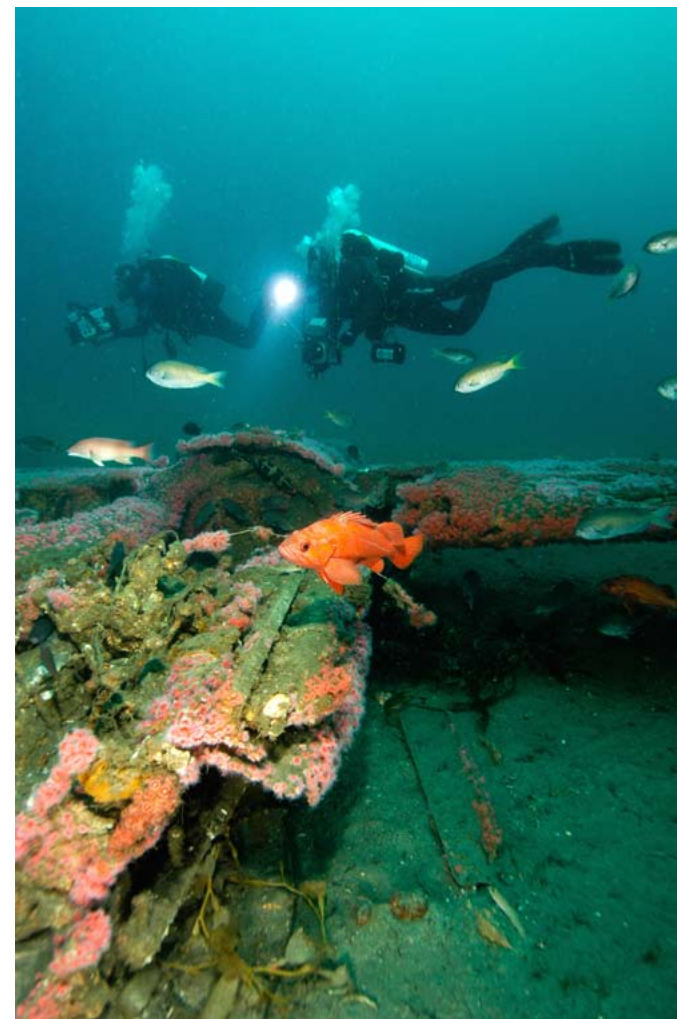

Two videographers hover over the engine of a P-38 fighter plane from WWII off the coast of San Diego.

might be left to see it. Put your best shot right out front. Define your story in the first 30 seconds. Tell them what they are about to see and sell it. Save something good for a memorable finish, and fill in the rest with strong but not necessarily great footage. Above all, don’t overextend your quality clips and sequences to fill a time slot. If you’ve

only got two or three minutes of strong material, stop right there. Your audience will thank you.

Story Elements

The most common video produced by divers is the music video, with clips, sometimes unrelated, of marine animals. Music videos can work if the images are coherent and speak for themselves. Movies did this for the first 40 years of their existence.

The second most common is the trip video. This usually starts out at the airport, or divers on a boat, gearing up, jumping in, swimming, some animals, ascending, back on the boat, and a sunset. If you've ever surfed YouTube, you know what I'm talking about. In most cases, you'll tune out before the first minute is up. To see some examples of videos with strong story elements, open iTunes, click on podcasts, and look up "DiveFilm HD Video." Mary Lynn Price has curated nearly 150 short videos, most of them 5 minutes and less, from around the world. Nearly all of them tell a story, and best of all, they are free. It's a treasure chest of ideas for underwater filmmakers. Putting aside false modesty, some of my films are included. Following are a couple of examples.

Two years ago I went to the Bahamas to shoot tiger sharks, then to Guadalupe Island for great

whites. That's not unusual; thousands of divers had been there and done that. I wanted to show something different. It was called, "In search of a Man Eating Shark." I integrated statistics on shark attack fatalities (about 5 per year worldwide), comparing them with other causes of death, which ranged from texting while driving to smoking and mosquito bites. While showing and discussing the sharks, the statistics appeared as lower thirds. The final stat was 100 million sharks killed every year by people. And the closing statement was, "Most people who are afraid of sharks have never met one." (ehanauer.com/Videos.html)

On another occasion I accidentally left my camcorder running in the rinse bucket and inadvertently caught another camera banging against it. That was the genesis for "View from the Rinse Bucket." The story was told from the point of view of the camera. It complains that it does all the work and is exposed to all sorts of hazards, while Eric takes all the credit. Clips from various locations were integrated, all of it narrated by the camera. It finally concludes that camera life isn't all bad, that it's seen lots of interesting things, but ending up in the rinse bucket is the scariest place of all.

Common story elements may include emotion, visual appeal,



Get close and let the creature come to you.

action, unique moments, characters, newsworthiness, sense of place, and humor. Let's look at some examples.

Wounded warriors on a dive trip or a sea lion tangled in fishing line are emotional subjects. Visual appeal could be a swim through a kelp forest or a colorful coral reef. Sharks feeding, or marlins attacking a bait ball are action at its most intense. Unique moments might include a humpback whale mother and calf, or a manta cleaning station. An interview with a dive guide or a pioneer diver is character development. Diving after a typhoon or an oil spill is

newsworthiness. Sense of place could show fire walkers of Fiji or the stone money on Yap.

Humor is one of the hardest elements to pull off. Don't force it, and don't embarrass anybody. Some fishes are funny all by themselves, like frogfish and stargazers. I once flooded a camera (pilot error) and decided to make something out of a bad situation. So I had my wife, Karen, take it down without a housing. She tried to make it work, accompanied by rattling and crashing sound effects. Finally she took off the lens, looked inside, and finally tossed

it over her shoulder. It was called, “Don’t Try This With Your Camera.” (ehanauer.com/Videos.html)

In the movie “Bull Durham,” baseball veteran Crash Davis teaches rookie Nuke LaLoosh about using clichés in interviews. I can’t help laughing about that every time I hear an athlete on TV talking about teamwork and taking it one day at a time.

Underwater videos have their share of clichés. They include divers opening tank valves, jumping into the water, clownfishes, and most common of all, closing with a sunset over the water. Crash Davis would love it.

Building blocks

Editing a video is a lot like writing. When I first sat down to write this article, I had a bunch of jumbled ideas. I wrote them down as they came into my mind, then started out by expanding the ideas that came easily into one or two paragraphs. Eventually I moved on to the ones that needed more thought and more research. Finally I shuffled all the sections around to make a coherent story.

In video, clips correspond to sentences. Put together a few related clips into a sequence, and that corresponds to a paragraph. Continue to build sequences, then rearrange them to make a coherent video. You

don’t have to start at the beginning, because there is really no beginning or end until you see how the sequences flow into one another.

Some stories write themselves. You start with a bang and power through. Others have to be constructed bit by bit, sometimes starting in the middle and slogging to the end. Either way, once you’ve got some momentum going, it can carry you to the finish. The same process applies to video.

Don’t be a slave to chronology. Starting at the beginning isn’t always the best way. If the most interesting sequence occurred in the middle of your trip, use it as a lead or a teaser to grab the viewers’ attention. News reporters always try to cover the most important parts (who, what, when, where, how) in the first paragraph, then taper off as they reach the end. Most readers never make it that far. In the news business, failure to do that is called burying the lead.

Master the technology of shooting and editing. In last month’s article we covered the mechanics of white balance, focus, frame rate, and steady shooting. When editing, look critically at your footage. If it’s not sharp, trash it. If it’s shaky and can’t be corrected, use it sparingly and only if it’s essential to the story. Work on color correction and exposure in post. If you can’t correct it, trash it. People



will judge you on your worst clips, so show only your best. Just as the secret to good photography is a big waste basket, the secret to good video is a big digital trash bin.

Length

How long should your video be? It depends on your audience and your material. When I started shooting video, I went on a trip to New Zealand and shot about three hours of tape, on land and underwater. I edited it down to 20 minutes. About that time I became involved with the San Diego UnderSea Film



Exhibition. (sdufex.com) Now in its 15th year, it has become one of the most prestigious shows of its kind. I wanted to enter, but they had a maximum time limit of 5 minutes for each entry. I asked for an exemption, explaining that I’d already cut it down from three hours. They refused, so it was back to the edit room. When finally finished, I had to admit the 5 minute version was tighter, better, and more interesting than the 20 minute version.

Shorter is better. The sweet spot for YouTube videos is about 2 ½ minutes. Anything longer than

that has to be really good to hold a viewer's interest. Respect the audience's time, and move the story at a lively pace.

If you watch old movies on Netflix or TCM, you'll be struck by the languid pace of most of them. People now expect to see the plot develop early on, and to keep moving. More action is crammed into shorter time.

Voice-over

When I started out, I didn't like the sound of my own voice, and did everything possible to avoid narrating my videos. But after a while I realized how essential it was for moving the story.

You don't have to sound like Ron Burgundy to do a successful voice-over. Just be yourself and carry on a conversation with the audience. Avoid talking too much; let the images speak for themselves. Research your subject, and become an expert on the fishes and marine animals in your video. Add something to the images instead of just telling the audience what they are seeing. Fill them in on the background that isn't apparent. Talk about the life cycle of the animals, or about the location, or about what it took to make the images. When the sequence is mandarin fish mating, talk about how this happens only at sunset, that you had to wait

an hour for 5 minutes of action, that males joust for mating opportunities, that cardinalfishes lurk in the coral, waiting to eat the eggs.

This can't be done off the cuff. Write the script as you watch your footage. Practice reading it while watching it again, making corrections and deletions when you see how it fits. When you are ready to record, use a high quality microphone, not the one built into the camera. You'll need a mike or a voice recorder that has balanced sound and doesn't sound tinny. Good ones start around \$100.

Do the recording in a room with favorable acoustics. Wood or tile floors are echo chambers. A clothes closet with a carpeted floor absorbs echoes and can serve as a makeshift recording studio. Record each sound clip two or three times, using different emphasis and inflections. Counting down 3-2-1 before each take will help when editing. Speak in your own conversational tone; don't try to be a news anchor. If you really hate the sound of your voice, recruit a friend. One local filmmaker had a woman with a British accent do his narration. It sounded very classy, like something from PBS or BBC.

Music

I always thought Enya's music was made for underwater, and used it in my early efforts. Most filmmakers



Get close and let the creature come to you. (This also goes with 9 and 10)
3. Final Cut Pro X is an example of video editing programs that bring professional capability to anybody with a fast computer and the will to learn.

start out using one of their favorite songs as background music. Here are some reasons that's a bad idea.

First and foremost, music is copyrighted. That 99 cents you paid on iTunes only buys you the right to play the song on your electronic toys. Using it on a film that will be shown online, or in an exhibition, isn't covered, even if you showing it for free. As a fellow creative artist, how would you feel if somebody used your video in their work without your permission? YouTube rejects these, although a few fall through the cracks. The vast majority of competitions

automatically disqualify entries that use copyrighted music without signed permission from the artist's agency. For big time artists, that will cost big bucks if they even bother to respond to your inquiry.

Another reason is that a popular song may overpower your images on the screen in the audience's mind. So what's a filmmaker to do? If you have musical ability, there's software that allows you to write and orchestrate your own. Garage Band and Soundtrack in the Mac world, and Sony ACID Pro on PCs are examples. Or perhaps you know a musician



Chuck Nicklin checks out a point and shoot

YouTube, a longer one for entry in a competition, and perhaps a longer one yet for presentations to groups.

If you've shot wide, medium, and tight you have the building blocks for your story. Get the attention of the audience at the beginning and leave them with something memorable at the end. For example, a film about manatees can finish with a full face closeup and you could say, "Beauty is in the eye of the beholder." In a film about diving in Alaska, finish with a clip of divers in a hot tub saying, "Glacier diving was fun, but sitting in the hot tub is even better." If your subject is macro, you can close with a famous quote from Robert Capa: "If your pictures aren't good enough, you weren't close enough."

Eric Hanauer



who is willing to write and perform something that fits your video.

What most of us do is purchase royalty free music. Just Google it and you'll find dozens of sources. Some of them are even free. One that's unique is Sonicfire Pro (smartsound.com). These tunes can be stretched or contracted to fit your clips and sequences, as well as changing tempos and even instruments. It comes at a somewhat higher price, but lends a more professional, polished sound to your efforts.

Leave them thinking

You might make different versions of your film for different purposes. One could be for

DPG ULTIMATE EXPEDITION: ANTARCTICA

MARCH 2015

JOIN DIVEPHOTOGUIDE FOR AN
UNDERWATER PHOTOGRAPHY TRIP UNLIKE ANY OTHER

MORE INFO: UWPHO.TO/1cBxUIJ

EMAIL: TRIPS@DIVEPHOTOGUIDE.COM



Lembeh Workshop

by Paul Macdonald

It was with great excitement that we boarded the boat to head off on the first dive of our Lembeh Strait adventure. Before we knew it we had rolled into the warm 27 degree water and critter hunting amongst the black volcanic sand. The macro life here is simply amazing with some of the strangest creatures.

We had arrived at Eco Divers the day before coming from Adelaide, Elizabeth and I leading a group of 4 other underwater photographers. Eco Divers Lembeh offers a very unique resort and dive experience. Nights are spent in the comfort of a resort and the day is spent diving from a day liveaboard.

They provided us a personalized service that was without equal. The resort caters for a maximum of just 16 divers. The rooms, all with air conditioning and ensuite bathrooms were immaculately presented and very comfortable. And close to every room was an indoor camera room with charging points, desktop computer and ample workspace. We also had free WiFi connection throughout the resort.

The meals at Eco Divers Lembeh were divine with numerous choices

on the menu that catered for all tastes. Breakfast and dinner was served in the open air restaurant where we would gather with others to discuss all things diving and underwater photography.

Our hosts at Eco Divers were Tarkan Sever and Kathrin Heussner. Both were very amiable and made our stay extremely comfortable. They did everything with a smile and nothing was too much trouble.

Dives were organised in a very unique way. In the morning around 8 am we left the resort and travelled by air conditioned vehicle to a wharf about 15 minutes away. Here we boarded a speed boat which took us out to the Eco Divers day liveaboard. For the length of our trip our dive gear remained on the liveaboard and was set up for us by the friendly staff prior to each dive. All diving in the Lembeh

All images shot with a Nikon D700 in a Sea & Sea housing with Sea & Sea strobes and a 105mm macro lens.

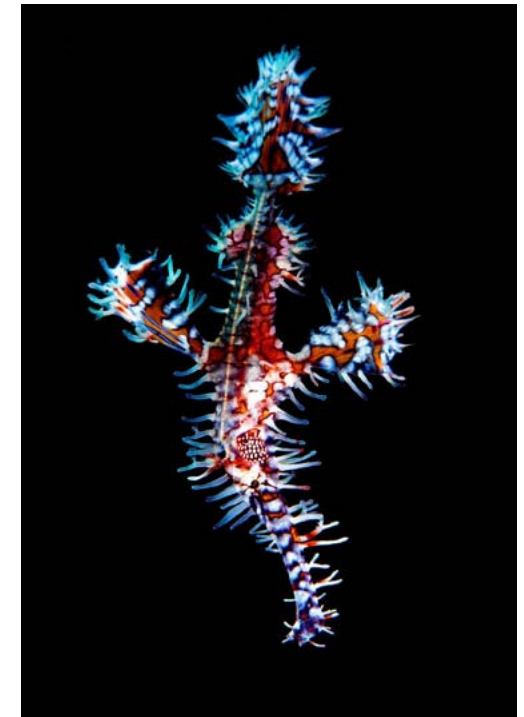

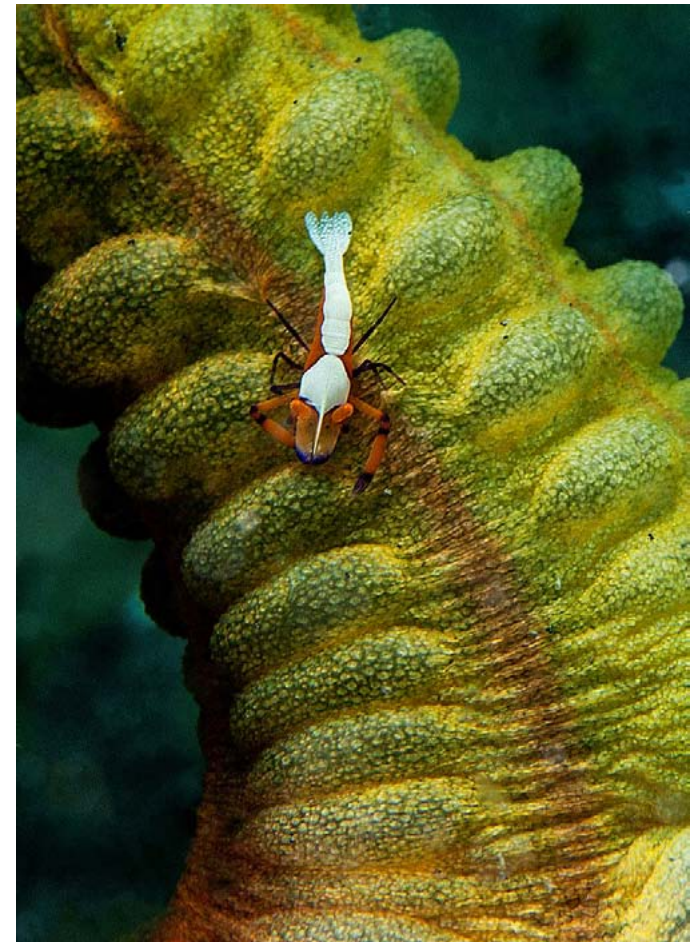

Strait emanated from the liveaboard which would moor only a few minutes by speed boat away from the days dive sites. The purpose built liveaboard had WiFi, battery charging points, large freshwater tubs for soaking cameras after dives, toilets and showers, a sunbathing deck, a spacious dive deck and a comfortable saloon where one could sit and relax between dives. We had 3 dives per day with the option of a night dive also.

Prior to each dive a briefing was provided by the very knowledgeable divemasters. Then it was off in the boats to the various dive sites to enjoy the Lembeh underwater world. Diving is over gently

sloping black volcanic sand or on reef walls. The black sand makes an excellent backdrop to allow underwater photographers to isolate their subjects.

When I first descended to the bottom and saw nothing but black sand I thought myself “what am I doing here”. Then with the help of the guide a whole new world opened up. The sand isn’t as barren as it first appeared and there were all sorts of fantastic things to see. Soon you are overwhelmed by the macro life that presents in front of your camera lens.

Our divemasters Horine, Man and Lorens were amazing, they could spot the tiniest and most well

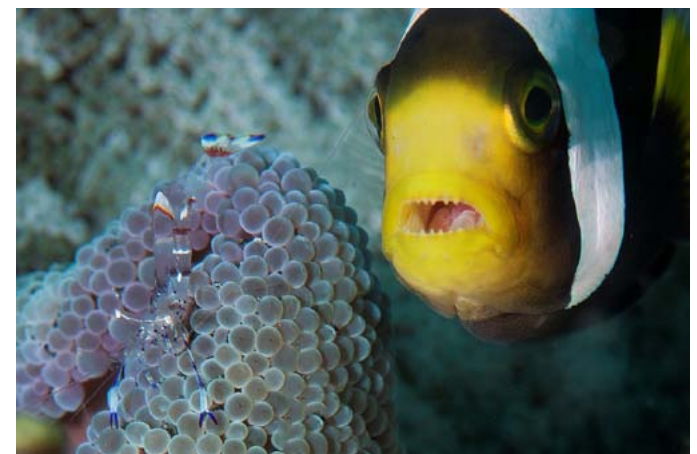



camouflaged creatures easily. And with a maximum of only 4 divers per guide, there was plenty of time for all of us photographers to work with our subjects. It really is a macro photographer's paradise and over the course of the trip I didn't once consider using a wide angle lens.

Whilst we were there, I conducted a number of underwater photography workshop sessions for our participants to help them get the most out of the photographic opportunities that presented

www.uwpmag.com

themselves whilst they were there.

So if you are into weird and strange marine creatures and / or nudibranchs then Lembeh Strait is for you. In fact it was so good that we are going back there again in June / July 2015. Again the trip will be limited to 6 divers including Elizabeth and myself. If you would like to join us for more information email me.

Paul Macdonald
paul@downunderpix.com
www.downunderpix.com

Gulf Gobies

by Alex Tyrell

The small island of Koh Tao situated in the Gulf of Thailand is not really renowned for its macro life. The general consensus amongst visiting divers is that they want to see the big stuff and swim along blissfully unaware of the smaller inhabitants of the reef.

Turtles, Groupers, huge schools of Barracuda or Trevally are high up on the wish-list of the majority and it doesn't take long for the word to get around the island when the coveted Whaleshark has been spotted on a dive site. These larger ocean denizens steal the limelight from the smaller creatures of the reef, which are simply not that appealing to a new diver that has been wowed with stories from their Instructor or Divemaster of encounters with a huge spotty fish.

I'm sure though, that some of the more experienced dive professionals would be interested in the macro life found here, but when you are swimming backwards and counting heads, the safety of your students being paramount, hunting out tiny creatures takes a back seat. And for the dive guides with divers fresh from their Open Water course, conducting a prolonged search a particular fish or

crustacean that your divers are really not that interested in, will probably mean they do not ask for you to be their guide the following day!

But for those that know where to look, the Gulf of Thailand has more critters than you would first think, though not in the abundance of countries found a little further east that fall inside the boundaries of the coral triangle. It doesn't take too much searching to find Urchin Clingfish, Monofin & Threadfin Dartfish, Hingebeak Prawns, Highfin & Shorthead Fangblenny, Bicolor Blennies, Xeno Crabs and Whip Coral Shrimps, to name a few.

On occasions I have also seen mouth-brooding Cardinalfish of various species, Sawblade Shrimps, Cleaner Pipefish, Seahorses, Slender Seamoths, Spiney Devilfish, and a variety of elaborate Nudibranchs, though I have to admit there are probably about 10 species making up the common slug-sightings and the remainder are slightly more rare.

One fish that we do have in droves though, which are continually ignored are Gobies, especially Shrimp Gobies that can be found on every dive site that has coarse sand or



Metallic Shrimpgoby (Amblyeleotris latifasciata) & Tiger Snapping Shrimp (Alpheus bellulus). Nikon D7000, Subal ND7000, Nikkor 105mm VR + Kenko 1.4x TC, Inon Z240 x 2. f/16 – 1/320th – ISO200

rubble substrate. We may not have the more sort-after species that I have seen in the Philippines and Indonesia, like the Magnificent Shrimp Goby or Yellownose Shrimp Goby, but we do have quite a variety and a few of them in significant numbers.

Gobies are the largest family of marine fishes with over 1700 species in 251 genera currently classified. Approximately 500 species in 212 genera inhabit the Indo-Pacific region, however many species still remain unclassified. A large group of gobies

live on the open sand and due to the ever-present danger of predators some of these species will excavate an underground dwelling. However a large number of the species, known as Shrimp Gobies, live in a symbiotic relationship, sharing a burrow with Snapping Shrimp from the genus *Alpheus*. The nearly blind shrimp needs the sharp-eyed gobies to spot, and then warn, of danger whilst the goby utilizes the shrimp's ability to tirelessly construction a network of burrows under the sand



Red-Margin Shrimpgoby & Tiger Snapping Shrimp (*Amblyeleotris rubrimarginata* & *Alpheus bellulus*)
Nikon D7000, Subal ND7000, Nikkor 105mm VR, Inon Z240 x 2, f/16 – 1/320th – ISO100

for somewhere for them both to live, as well as providing a safe refuge when danger threatens.

Shrimpgoby Shooting Techniques

The key to getting close to Shrimpgobies for good shots, apart from having plenty of patience, is to understand how they interact with their symbiotic partners, the shortsighted Alpheid Shrimp. This enables us to read the warning signs of when they

are about to disappear down the burrow, so we know when to stop our movements and allow them to settle back down before we carry on shooting.

When the goby perceives a threat of danger, it will back up so that the shrimp's antenna rests against its tail and will alert the shrimp by moving it in a rapid twitching motion. The shrimp will then quickly back off into the burrow, and if the treat continues, will be swiftly followed by the goby.



Banded Shrimpgoby (*Cryptocentrus cinctus*)
Nikon D7000, Subal ND7000, Nikkor 60mm, Sea & Sea YS-250 Pro & Saga Optical Snoot, f/10 – 1/320th – ISO200

The burrow opening will then collapse on the pair, trapping them both safely beneath the sand.

After a period of time, and this can vary greatly from species to species, and even within individuals of the same species, the goby will reemerge from the burrow to check if the coast is clear. If it is, the goby will once again signal to the myopic shrimp, albeit under the sand and out of sight, who will then reemerge to commence clearing the burrows opening, moving sand and rubble out of the way, leaving the opening clear and ready for the next dash to safety. As both Shrimp and Goby benefit from this relationship, it is known as mutual symbiosis.

It therefore goes without saying that a calm approach is required. Any sudden movement of the camera, an overly swift repositioning of the strobe, a too quick hand movement to adjust strobe power or even just turning on a bright focus light can send



Banded Shrimpgoby Yawn (Cryptocentrus cinctus)
Nikon D7000, Subal ND7000, Nikkor 105mm VR + Kenko 1.4x TC, Sea & Sea YS-250 Pro x 2. f/14 – 1/320th – ISO100

them scurrying down their burrow in a cloud of sand. I have found that selecting the 'right' individual vastly improves the chances of a good shot. Some are very shy and will retreat well before you are within shooting range. Whereas others are a little more bold, allowing a much closer approach. I have also noticed that when there is a mild current (we do not get much in the way of currents on the majority of Koh Tao dive sites) it can promote feeding behavior.

As plankton drifts past the

burrow, the Shrimpgobies will venture a little further afield than normal, enticed by an easy meal and seem to become a little preoccupied, ignoring the camera being inched towards them. This is when I have captured some of my favourite shots, as the whole fish is in view with mouth agape. So I normally start by observing the different individual gobies and then select one based on the behavior. I sometimes even test an individual's tolerance to me by getting the camera close without taking a



Steinitz's Shrimpgoby (Amblyeleotris steinitzi)
Nikon D7000, Subal ND7000, Nikkor 105mm VR, Inon Z240 x 2. f/16 – 1/320th – ISO100

shot, simply to see if it immediately darts into the burrow. If it passes the test, showing potential for a close approach, I will settle down to shoot.

The most common of our Shrimpgoby species is either the Banded Shrimpgoby (*Cryptocentrus cinctus*) or the Steinitz' Shrimp Goby (*Amblyeleotris steinitzi*). The Banded Shrimpgoby is the more photogenic, coming in two colour variations, either bright yellow or dark brown. The yellow is the more striking colour morph, but both have vibrant electric

blue spots over the facial region, dorsal and ventral fins, as well as the same coloured bands along the anal and second dorsal fins, which make for great images if you time your shots for when they splay their fins, which normally occurs when feeding. Juveniles of the species are a much brighter colour, but lack the blue lines and spots of the second dorsal and anal fins.

Another very common species that, at first glance, seems very similar in appearance to the Steinitz'

is the Red-Margined Shrimp Goby (*Amblyeleotris Rubrimarginata*). Both are coloured light creamy-white with slightly darker orangey-brown bands, but when lit up with strobos the bright red margins on the dorsal fins become visible and they also have much more ornate marking on the caudal fin, however lack the yellowy-orange stripes in between the bands of the Steinitz'.

A favourite of mine is the Wide-Barred Shrimpgoby (*Amblyeleotris latifasciata*) also known as Metallic Shrimpgoby. These do not look that pretty when first observed, seeming to be a fairly dull, dark-brown hue, plus they are quite timid, usually backing into their burrow as soon as you approach leaving only their head protruding. But when lit up with a dive light or your strobos, the bright red, orange and blue markings become visible and if you get to see the whole fish, they have an extremely ornate pattern on the ventral, anal and caudal fins, accompanied by a shimmering metallic look, hence the alternate name.

These stunning little fish do however require a more patient approach than the aforementioned species, being infinitely shy and are quick to vanish into their burrow, sometimes taking an extended period of time to re-emerge. These are not as common as other species, though I have found them on a number of dive sites around the island that have the preferred fine-rubble substrate. Strangely, there is one small area on a particular site that has quite a few individuals living in very close proximity to each other, that I have not encountered elsewhere.

Other species of goby that can be found include, but are certainly not limited to, Nakedhead Shrimpgoby (*Amblyeleotris Gymnocephala*), Barred Shrimpgoby (*Cryptocentrus fasciatus*),

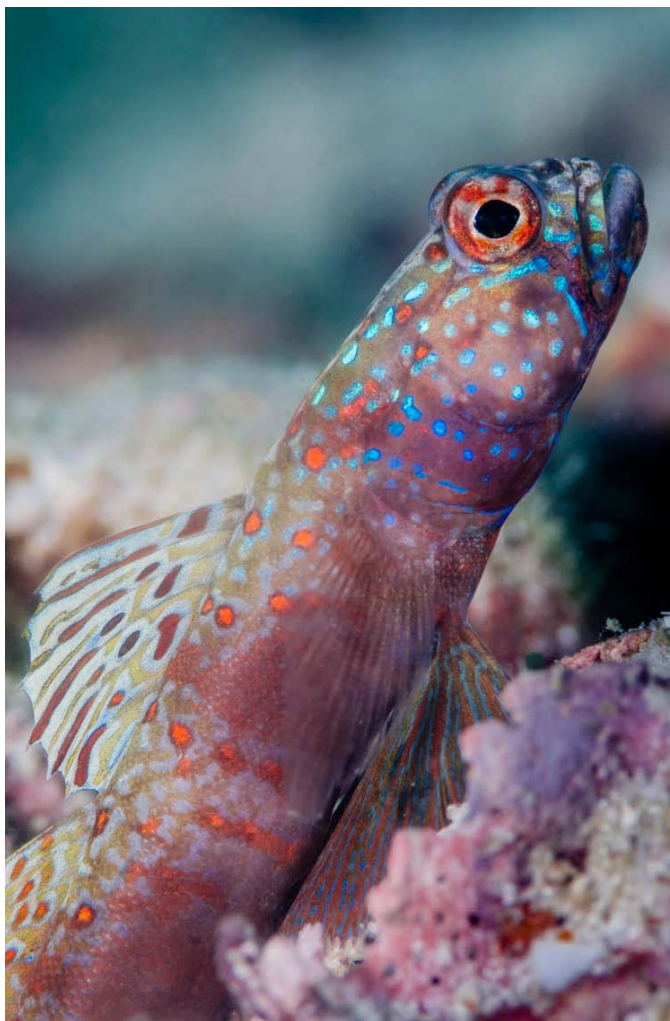

Metallic Shrimpgoby (Amblyeleotris latifasciata)
Nikon D7000, Subal ND7000, Nikkor 105mm VR + Kenko 1.4x TC, Inon Z240 x 2. f/16, 1/320th. ISO200

Saddled Shrimpgoby (*Cryptocentrus leucostictus*), Whitecap Shrimpgoby (*Lotilia graciliosa*), Signalfin Goby (*Coryphopterus signipinnus*) as well as Whip Goby (*Bryaninops* sp.) and Banded Goby (*Amblygobius phalaena*). My friend Alan from Koh

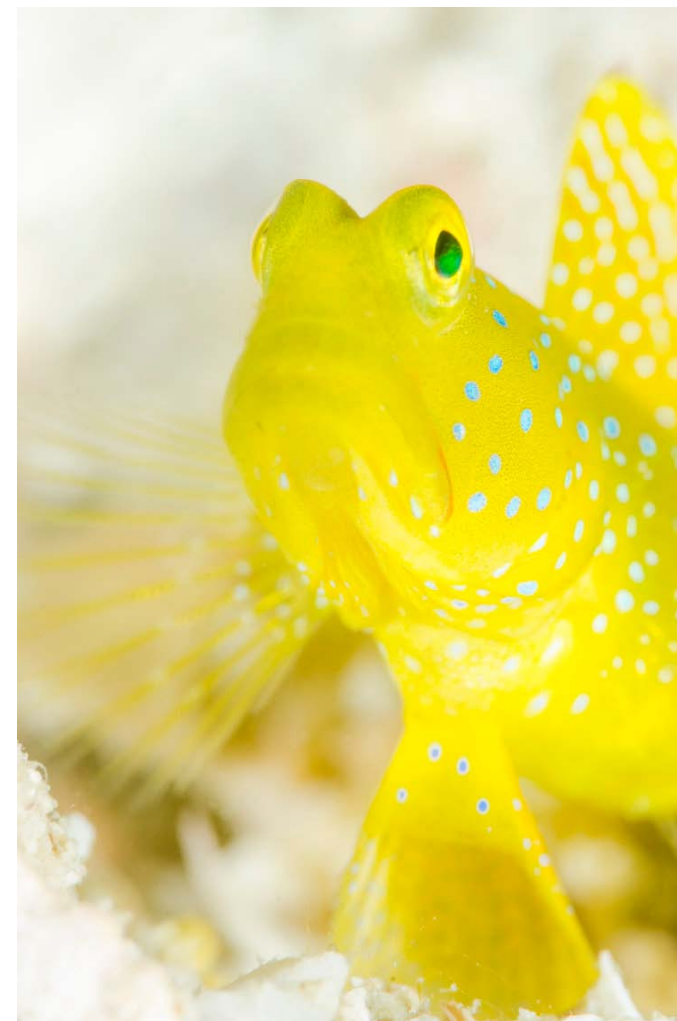

Banded Shrimpgoby (Cryptocentrus cinctus)
Nikon D7000, Subal ND7000, Nikkor 105mm VR + Kenko 1.4x TC & SubSee +5, Inon Z240 x 2. f/25, 1/320th ISO200

Phangan has 40+ different species in his catalogue, so I have plenty more to find.

A recent obsession of mine is the Five-Lined Coralgoby (*Gobiodon quinquestrigatus*) that lives within branching *Acropora* coral. These are tricky



Five-Line Coral-Goby (Gobiodon quinquestrigatus)
Nikon D7000, Subal ND7000, Nikkor 105mm VR, Inon Z240 x 2. f/22 – 1/320th – ISO100

little fellas to shoot, apart from being quite small at a maximum size of 3.5cm, they are constantly on the move. But the more troublesome factor is the environment that they are found. The coral branches cause shadows in your lighting, create distracting out of focus elements in the foreground, sometimes over-expose being a lighter colour than the gobies, or simply obscure your view!

Once again subject selection is key, but you don't start with the fish. Choosing the 'right' coral comes first,

as you need to find one that contains gobies and ideally has good access, so you can settle down without being in a too confined area that could result in inadvertent damage to other corals. Then you need to study the pattern of movement of the gobies, as they tend to have a route within the coral that they will continually follow.

This route needs to take in the edge of the coral, plus the fish needs to pause here, for the opportune shooting moment. So quite a few factors have to coincide, which has



Barred Shrimpgoby (Cryptocentrus fasciatus). *Nikon D7000, Subal ND7000, Nikkor 105mm VR, Inon Z240 x 2. f/16 1/320th, ISO100*

caused me to search in excess of 30mins before settling down to shoot, even though we have these Acropora corals all over our reefs, the majority containing the fish in question. I now have a few favourite corals that I will return to for productive photography of Five-Lined Coral Gobies, rather searching randomly. Expect to put quite a bit of time into capturing a good shot, as with the narrow field of view and magnification of near 1:1 of my preferred set-up of the 105mm, sometimes with a Kenko 1.4

Teleconverter to exceed 1:1, they are quite hard to find in the viewfinder. You really have to predict where they will pause for that moment and wait there with you eye glue to the viewfinder, ready to grab a single shot, when (and if) they come into frame. After lots of frustration, I now set my lens to maximum magnification and then rock in and out for focus, having missed too many shots with AF hunting. I have also found that searching around the coral or trying to follow the fish is



*Shrimpgoby Sunset – Banded Shrimpgoby (Cryptocentrus cinctus)
Nikon D7000, Subal ND7000, Nikkor 60mm, Sea & Sea YS-250 Pro
f/20 – 1/25th – ISO100 – Backlit Red-Gelled Strobe*

unproductive, as well as shooting when there is any surge, which just becomes annoying with the shallow DOF you get from shooting this close to a subject, making sharp focus truly a matter of luck.

My next quest is to look for other species of Coral Gobies that I think can be found in our waters. I have seen these in Indonesia and the Philippines, which are commonly grouped together as Hairy or Bearded Gobies. I am yet to find the correct host coral (*Seriatopora hystrix*) for the

Yellow Coralgoby, but think we have the Cauliflower Coral (*Pocillopora damicornis*) that is the host for both the Blackfin Coralgoby (*Paragobiodon lacunicolus*) and Warthead Goby (*Paragobiodon modestus*). I also plan to check out some of the deeper dives sites for different Shrimpgoby species, as in the past I have always set up for wide-angle, shooting reefscape in the clearer water or pelagic encounters that are more likely offshore, ignoring the smaller stuff. The search continues!

References:

- Encyclopedia of Life (www.eol.org)*
- Fish Base (http://www.fishbase.org)*
- Reef Fish & Reef Creature Identification - Indo-Pacific (New World Publications)*
- Alan Duncan – The Dive Inn, Koh Phangan (http://www.the-diveinn.com)*

Thanks to Dive Point Koh Tao for supplying a great dive boat to work from and allowing extended dive times to search out the different species found in our waters.

Alex Tyrell

Alex operates Dive4Photos, Thailand's only dedicated underwater photography training facility, located on Koh Tao in the Gulf of Thailand. He also runs regular Photo Workshops & Photo Tours at various destinations around Asia.

www.dive4photos.com
www.atyrell.com

ANILAO UNDERWATER PHOTOGRAPHY TOUR

11th - 21st APRIL 2015

HOSTED BY ALEX TYRRELL & MIKE BARTICK AT CRYSTAL BLUE DIVE RESORT









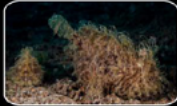







10-night dive package - 26 day & 3 night dives (Nitrox Included)
full-board deluxe accommodation + dedicated camera room
60-90 minute dives - 4:1 diver/guide ratio on private boat
critique sessions, tips & advice from Photo-Pros Alex & Mike
photography technique & natural history presentations

Only US\$ 1,998 + return transfers from Manila





For further information email: info@dive4photos.com
or visit www.dive4photos.com & www.dive4br.com



Back issues



99p per issue or buy
the complete set of
81 issues for just
£19.95
(That's about
25p per issue!)
Yours to keep
forever.

As you know, the current issue of Underwater Photography is free to download but all of the previous issues, going right back to Issue 1, are still available to download for just 99p per issue. It's a fantastic reference library chronicling all that has happened in underwater photography over the past 13 years.



Add UWP58 to cart

UWP58 — Jan/Feb 2011, 76 pages.

[Click to show or hide issue contents](#)



Add UWP57 to cart

UWP57 — Nov/Dec 2010, 85 pages.

[Click to show or hide issue contents](#)



Add UWP56 to cart

UWP56 — Sept/Oct 2010, 90 pages.

[Click to show or hide issue contents](#)



Add UWP55 to cart

UWP55 — July/Aug 2010, 75 pages.

[Click to show or hide issue contents](#)

Buy back issues
here

South West Ramblings 11

by Mark Webster

It is always a little sad to me to observe the days gradually getting shorter and the temperature slowly getting cooler as the season changes from summer to autumn. The dog days of summer may be here as I write this instalment, but we are in fact enjoying a splendid Indian summer with plenty of calm sunny days. Unfortunately working away from my home in the south west means that I have missed many of these perfect days, but those days that I have been able to dive have been very productive. Early autumn is often very active with many species putting in some enticing cameo performances before disappearing for the winter months.

As underwater photographers we are essentially hunters seeking a target to capture with the camera. But unlike hunters or wildlife photographers on land we do not have the luxury of being able to capture an image from a distance, or conceal ourselves, and most of the time remote systems are impractical. We need to get close to our subject for a number of reasons and that means that your subject is very much aware of your presence and approach, so for good images we

really rely on the trust and cooperation of the animal. The first challenge of course is to find the desired subject and then be armed with the correct lens to capture it and hopefully have the right conditions to produce a successful image. The gods of underwater photography do not often align in this way but when they are close we can significantly improve our chances with the correct approach.

One of our favourite dive sites is close to the mouth of the river Fal. The estuary is quite wide where it meets the sea and there are wide relatively shallow areas on both sides bordering the deep central channel that is a product of a drowned river valley, which provides Falmouth with one of the deepest natural harbours in the world. The low headlands on each side of the estuary funnel the strong tidal flow with each change of the tide and create all sorts of eddies and back flows which results in high levels of nutrients over these shallow areas. This of course attracts marine life, both sessile and predatory, amongst the patch reefs and sandy areas here which offer great habitat diversity and the chance to get close to some good subjects.



We can become so focussed on the hunt for a particular subject that we run the risk of missing a more obvious and perhaps co-operative one. I was following a cuttlefish and suddenly realised that this deep orange gurnard was just a few inches away from me and obviously not spooked by my presence or the camera. Nikon D7100, Subal ND7100, 10-17mm FE zoom, Inon Z240 flash guns, ISO 200 f11 1/100.

We often dive this area after a deeper reef or wreck dive in the bay, so the camera is normally equipped with a fish eye zoom lens unless I make a change to a macro lens on the boat. So I am usually looking for opportunities to create some CWFAs images with my fish eye zoom with hopefully cooperative subjects. In early autumn there are normally lots of medium sized cuttlefish here

resting and feeding and it was these critters that I was seeking on three different dives that produced three different interactions and some very pleasing images.

In the last episode of ramblings I briefly described an encounter with a very patient red gurnard which only occurred as a result of following several cuttlefish who were not cooperating on that day. You can



As this cuttlefish got even bolder and came close enough to feed on fish directly in front of the housing it adopted this very striking dark brown/black and white pattern which provides terrific contrast with the negative space. But what is it all about? Nikon D7100, Subal ND7100, 10-17mm FE zoom, Inon Z240 flash guns, ISO 200 f11 1/125.

become very focussed on the search for a single subject and consequently miss an opportunity with another that maybe more cooperative. In this case I had settled down to make a slow approach towards a slightly nervous cuttlefish when I noticed a red gurnard on the edge of my view through the viewfinder that seemed totally unconcerned about my proximity, which is unusual for this species. I turned my attention to this new subject and as a result captured a

set of images which showed this fish from a variety of angles and poses and in extreme close up to the dome of the housing. This interaction lasted more than 30 minutes and would have continued if I had not been low on air. The gurnard kept approaching me, climbing over bits of weed, occasionally stopping for a quick scratch in the sand, but most definitely intent on getting closer. This is very unusual behaviour for most fish and I kept shooting thinking that it must



The colour of the cuttlefish when striking at prey varied just as dramatically, but the one common theme seems to be the warty appendages that appear on its back. When he relaxes again after catching the fish then these smooth out and disappear. The strike starts slowly but ends very quickly and it often difficult to capture. Nikon D7100, Subal ND7100, 10-17mm FE zoom, Inon Z240 flash guns, ISO 200 f11 1/125.

get spooked soon. But that didn't happen and I finished the dive very happy thinking this will not happen again, but I would be proved wrong by another fish species in a couple of weeks.

In between I continued to pursue cuttlefish who are masters of camouflage and often like to rest on the seabed partially buried, so you have to look hard and be prepared

for disappointment as many will take flight as you approach. Quite often you might be surprised by a cuttlefish partly buried right in front of you watching warily. When this occurs try a different approach - don't stop, swim on as if you have not seen the critter without making eye contact and then slowly come to a stop a couple of metres away. If the cuttlefish holds position then be patient and just

observe for ten minutes or more and then maybe try a couple of flashes to see if the subject reacts. I am not wholly convinced that flash upsets fish, seahorses or cuttlefish as they seem not to react at all when the flash is fired (do their iris react quickly enough to see the flash?) and often the only reaction is to the sound of the shutter. If the subject begins to move then follow slowly in parallel, don't rush to get in front of the subject which may make you appear more of a threat. To get close enough you need to wait until the critter accepts your presence and is confident that you are not a predator and this may take some time.

I followed this procedure with this particular cuttlefish and after some time it began to look less nervous and I could see it was beginning to look for prey, so I gradually moved closer. If your subject begins to feed when you are close then it is obviously relaxed in your presence and you may be in for a memorable experience. I watched the cuttlefish strike several times as I gradually moved in closer resting my housing on the seabed each time I stopped. The cuttlefish was feeding on small sand gobies that are normally very inquisitive and will be attracted by any disturbance in the sand that might reveal a meal for them. These gobies were gathering at the base



If you have a cuttlefish encounter with a macro lens don't ignore your subject. Once your cuttlefish is settled you can make a close approach for a single eye shot like this one. Cuttlefish and most other fish do not react to flash even in close up and I have photographed the same cuttlefish in the same location for several days in a row with no reaction. Nikon D7100, Subal ND7100, 60mm micro, Inon Z240 flash guns, ISO 200 f22 1/60

of my housing as it was contacting the seabed and the cuttlefish quickly realised that this might present an easy meal with me actually helping rather than hindering the hunt. Once he had made the first strike close to the housing I knew that this was going to be a special moment and in fact this feeding arrangement went on for nearly an hour and it was me that terminated it as I had to return to the surface!



Just a few days after my cuttlefish encounter I was back in the same area looking for another when this plaice caught my attention. Whilst a plaice does not perform like a cuttlefish, this one plainly wanted to make friends with me once it had accepted I was not a predator. Nikon D7100, Subal ND7100, 10-17mm FE zoom, Inon Z240 flash guns, ISO 200 f13 1/100.

As I watched the cuttlefish hunt I thought at first that I could tell when he was about to strike due to the change in colour and texture of the skin. To begin with he would turn very pale and warty appendages would appear on the back just before the strike which can start slowly with a gradual extension of the central arms, but the actual strike is very quick and I often missed it. As the hunt progressed I realised that the

pre-strike colour was not consistent but that the warty appearance seemed to feature most of the time. In fact the colour changed significantly with each location although the seabed texture and topography did not, so these changes did not appear to be for camouflage purposes. In fact at the end of the dive the cuttlefish was adopting a very bold dark brown/black and white colour as it fed on fish directly in front of the dome of

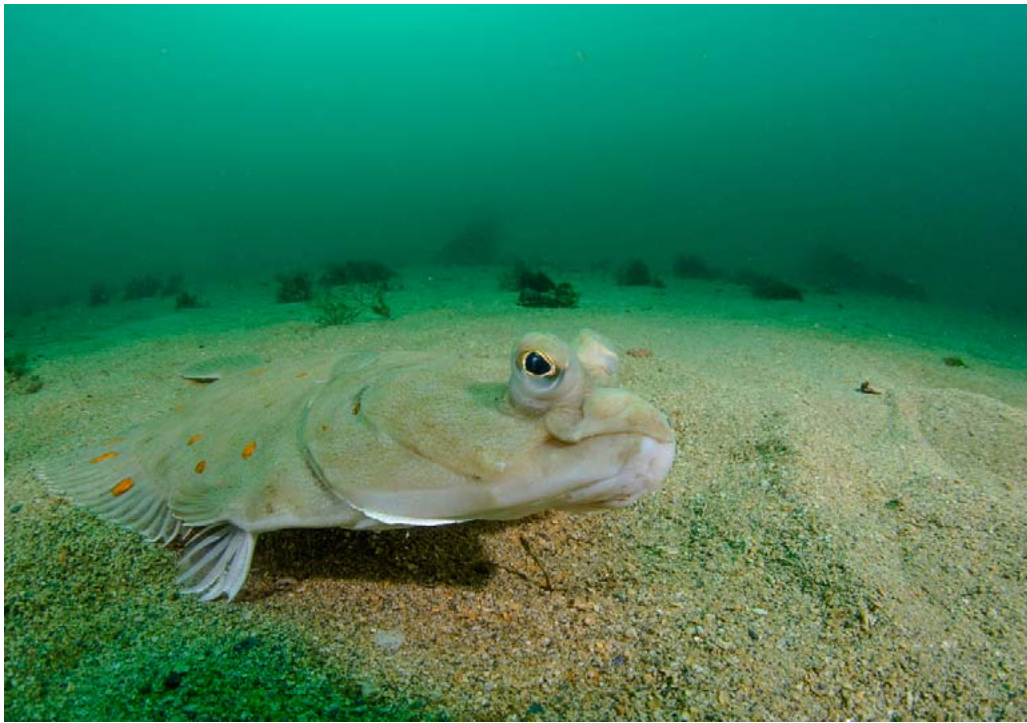

The plaice eventually left the kelp and weedy areas and followed it onto much finer sand. The plaice then seemed to give up on the hunt and just progressively moved closer and closer to the dome of my housing producing a fantastic interaction and some good images to remember it by. Nikon D7100, Subal ND7100, 10-17mm FE zoom, Inon Z240 flash guns, ISO 200 f13 1/60

my housing. Interactions with marine life large or small are a real buzz and I finished this dive thinking that for a photographer it does not get much better.

Just a few days later we were back on the same location at the same state of the flood tide so I was hoping that all the marine life would be just as active and that I might be able to make friends with another cuttlefish. I tried hard to make friends again

but no one was interested and I was beginning to think that this dive might not be so productive after all. It was then that I spotted a plaice peering out from under a piece of kelp which I almost ignored as they are often very skittish. But having found no willing cuttlefish I thought it was worth investing some watching time and an attempt to get closer. After ten minutes or more I began to move in and got to a metre or less and took

a couple of shots. The plaice rose up and swam away with graceful undulations of its flattened body and I thought the game was up already. As I watched the plaice it swam just a few metres away and settled on the heavy sand seabed and seemed to settle again so I moved in slowly for take two.

I got a little closer this time and perhaps shot four frames before the plaice moved off once more but did not go too far. We played this game for several more moves and it then appeared that the plaice finally decided that I was a friend and not a foe after all. He began to move towards me and actually fed a couple of times on the same small gobies that the cuttlefish favour. Thereafter I spent a delightful forty minutes or more shadowing the plaice and each time he stopped he got bolder until we reach the point of posing almost on the dome of my housing. So another happy dive, fantastic experience and interaction with wildlife and some good images to remember the event.

A few comments on lighting in these situations. When you are working on a sandy seabed often with some current running you can often run into some backscatter and flare issues particularly with a fish eye lens. Suspended sand particles can be caused by the current, your subject and your own movements, so you

can reduce your own contribution by consciously positioning yourself down tide of the subject. So at least the sand you disturb will move away behind you and anything coming towards you from the subject should pass by fairly quickly. The seabed will be very reflective and can cause flare and hot spots if you keep your flash guns low to the side of the housing. You can reduce this by positioning your flash guns more above and behind the housing and then adjust the angle to avoid backscatter. However, the exact position will change as you get closer to your subject and then you must watch for shadows cast by the housing or the shade on your dome port. Keep checking as you change position to fine tune the best set up.

Striking up a relationship with wildlife is always a pleasing experience and as photographers we also have the means of capturing that moment. The old saying goes “patience is a virtue...” and this is certainly true with marine life. For every dive that produces a connection and some good images there may be dozens that are dull and frustrating, but it is certainly worth the wait for those moments when it all comes together in front of the lens.

Mark Webster
www.photec.co.uk

www.uwpmag.com

Small ads



SOLD! – Ikelite housing for a Canon 5D MKII

Ikelite housing for a Canon 5D MKII, Ikelite 8" dome port (no scratches) for a Canon fish eye lens, Ikelite ports Canon 17-40mm and a macro 100mm IS lens. I am based in Scarborough, U.K. £1100 ovnoraminrobin@hotmail.com

Your advert could be [here](#) instead for just £5.00



For sale – extrem'vision(up to 100 m!!) and video camera sony vx 2000

I'm selling a fantastic underwater housing extrem'vision(up to 100 m!!) and video camera sony vx 2000 in really good condition!!!coming with a pelican case!!!!The underwater housing is coming with :- 2 lenses (1 macro and 1 wide angle) - 1 red filter. - 2 set of o'rings - Sillicon for the o'rings. - Digital screen.The sony camera vx 2000 is coming with : - A set of batteries (2 large,i medium,1 small) - 5 new dv tapes. - 2 cleaning tapes.Extrem'vision is a French Brand known worldwide.it's strong,reliable and easyto repair if any problems....REALLY GOOD CONDITION!!!!2000 euros!!!!!!fabien mouret

Email: maddox666@gmail.com [Ref:c147]



SOLD! – Subtronic Nova analog version no ttl converter

Subtronic-Nova-analog-version-no-ttl-converter

The strobe is 3-years-old-in-good-condition

All sockets in S6

800-€

Rudolf Sollböck

Ref C146

Your advert could be [here](#) instead for just £5.00



For sale – Aquatica housing 5D, 8 inch dome, dome shade and canon 5D body

Aquatica housing 5D, 8 inch dome, dome shade and canon 5D body including 2 spare batteries and spare charger for sale £1600 + p&p.Housing:Aquatica 5D housing - good to 90m, 8" optical acrylic dome port – some minor scratches but not visible in photos, 8" dome shade / guard, for wide angle lenses, Spare O ringCameraCanon 5D, 3 Batteries, 2 Chargers, StrapAll for £1600+ p&p, will accept paypal, or cashPlease feel free to ask any questionThe equipment has not been used for a while but I have just upgraded to a canon 5D mark II package so have this for sale.I am based in London and if you wish to come round and have a look/examine the equipment prior to parting with your money we can arrange that.

Email: martin.abela@hotmail.co.uk [Ref:c145]

Sell your stuff You'll be amazed at just how quickly your unwanted underwater photography kit could be converted into hard cash with a UwP small ad. You can have your own UwP small ad for just £5.00 and it can have one photo as well as up to 100 words.

Check out small ads
here

Buy your small ad
here

Book Review

Underwater Photography

by Tobias Friedrich

by Dan Bolt

From the outset this lavishly illustrated book hits you with some stunning underwater imagery. The cover shot, aptly titled 'The Dark Knight' is just the beginning, with a beautiful two-page split-shot of a humpback whale coming just a few pages later and the quality of photography continuing at that level throughout all 200+ pages.

In Tobias' enthusiastic introduction he says that the best way to read this book is from front to back – and he's also correct to point out that you will read about terms and concepts in the early chapters that are not fully explained until later in the book. If you didn't know this and just chose, for example, to judge the book by simply reading the opening chapter on Equipment, then you would indeed think it was missing a lot of explanatory text to describe some of the fundamentals of photography beneath the waves. It is only when taking the book as a whole that all the pieces fall very neatly and concisely into place. In fact this book is definitely one of those publications that is greater than the sum of its constituent parts.

Following the well proven formula for such books, the chapter list starts out with a look at Equipment and progresses through the Basics of underwater photography and on to Composition. Additionally there are specific chapters on Wide-angle and Macro photography and the usual finishing pages about Image Editing.

It is worth noting at this point that its not until

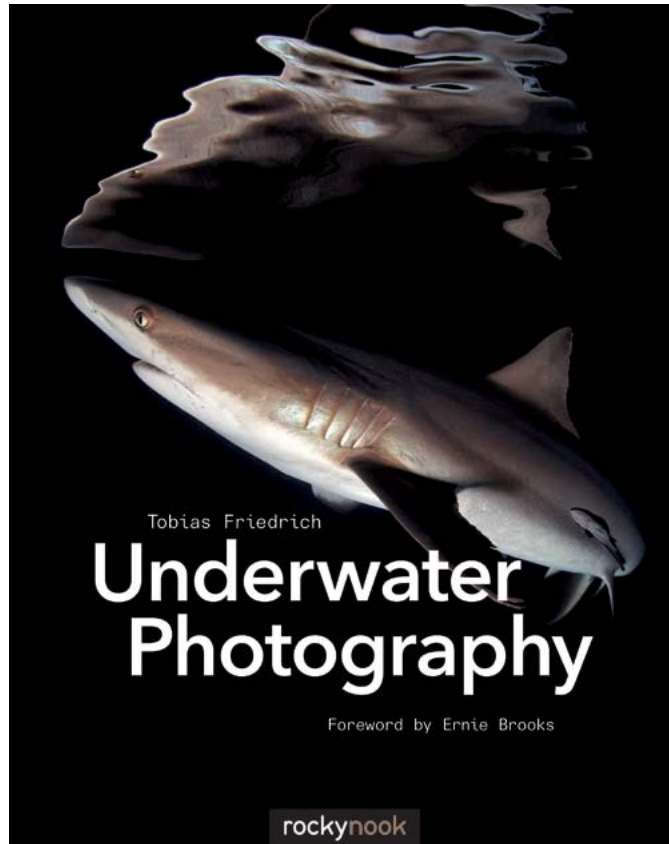

page 21 that you discover who the book is aimed at. To be honest though the opening line in chapter 1 (Equipment) gives a large hint at to the target audience: 'A compact camera produces passable images above the water, but below the surface of water its pictures are dull and boring'. So, plainly this book is aimed at DSLR users. In-fact you could go one step further and say it was aimed at relatively inexperienced underwater photographers who have just purchased a full-frame DSLR. The few times compact cameras are mentioned it is mostly in negative terms, with no mention of large-sensor compacts like the Sony RX100 series at all. Micro Four Thirds gets even worse treatment and is



Unexpected moments sometimes force you to compose an image on the fly; the risk of failure sometimes gives way to particularly attractive pictures
Seacam Canon EOS 5D Mark II • Canon 8–15mm fisheye lens • 1/200 s • f/18 • ISO 800

only mentioned in a comparison of sensor sizes.

One nice touch in the Equipment chapter is the emphasis on choosing wisely and prepare for a long relationship with your camera. Tobias is proof



Even when you use the best possible technique with artificial light, floating particles inevitably show up. Fortunately, image editing can take care of this problem.

Seacam Canon EOS 5D Mark II • Canon 8–15mm fisheye lens • 1/50 s • f/10 • ISO 400

that selecting the right camera and housing will lead to a very fruitful photographic partnership. Take, for example, the beautiful and varied images used to illustrate this book. From wide-angle to super-macro, and with just one single exception, every single image used was taken on a Canon 5DmkII. This is surely the best way to prove the point about kit selection.

Authors of books such as this face a choice about how to cover the potentially complicated issue of lighting our images. Tobias chooses to forego a dedicated chapter and instead uses a section within the Wide Angle and Macro chapters to explain how to light those specific types of image. I was a little disappointed with the lack of detail on lighting, but with a strong emphasis placed



Nudibranchs are favorite subjects for macro images, and they are easy to photograph because they move slowly

Seacam Canon EOS 5D Mark II • Canon 100mm macro lens • 1/125 s • f/20 • ISO 200

So called cleaning stations present great opportunities to capture well-composed photos while cleaner fish perform their service (although patience is required)

Seacam Canon EOS 5D Mark II • Canon 100mm macro lens • 1/125 s • f/18 • ISO 400

on experimentation to see what works best I guess the point is that there is no single set of rules on lighting. In fact this is how Tobias puts it: 'There is no right or wrong way to use flash, just optimal and less optimal strategies...'. This is probably true if you choose to shoot only in clear waters, but take it from me there are some very wrong ways of using flash in low-visibility scenarios!

I particularly liked the Composition chapter.



You might remember the last book I reviewed was dedicated to the subject, and I was a little concerned that actually too much detail was included for the average reader to turn it into useful, practical, advise. Tobias' attempt to explain what makes a pleasing image however, I feel, is spot on. Using yet more aesthetically pleasing photographs he describes the concepts we all use (consciously or not) to make the decision about when to take a

photograph. Further endearing me to the book were the two sections about Exceptions and Creativity also included in the Composition chapter. You can read all the rule-books you like, but without experimentation and creativity all our images will look the same.

Half-way through the chapters there are five Guest Photographer Galleries where some of today's most respected and creative photographers have contributed images and text, each demonstrating differing styles and subject selection. I won't spoil the nice surprise that these galleries are, but I will say that it was pleasing to see some images from the UK and I was even more surprised to realise that I am actually in one of the guest's photo's too... I will leave it up to you to guess which one is me.

The two chapters on Wide-Angle and Macro discuss all the relevant points about kit, subject selection, lighting, camera settings and different techniques that you would expect from a detailed book such as this. I did smile while reading about which colour wetsuit to ask your model to wear, but the point being made is perfectly relevant – too much black kit on your model can kill an otherwise perfectly good photograph.

Chapter number 6, the last one, is titled Image Editing but it actually covers quite a few more subjects that



just how to finish off your photos using post-processing techniques. There is also an informative section about getting your workflow honed into a smooth operation so as to save you time and effort, but I very much liked the section where Tobias explores Selecting And Evaluating Pictures. He specifically emphasises the point about choosing images; it is all about the image itself and NOT the emotion you personally might attach to the photo. Other people (including competition judges) will not know just how hard you had to work to get an image, or that it might have been taken on the best dive of your life. The image should be selected because

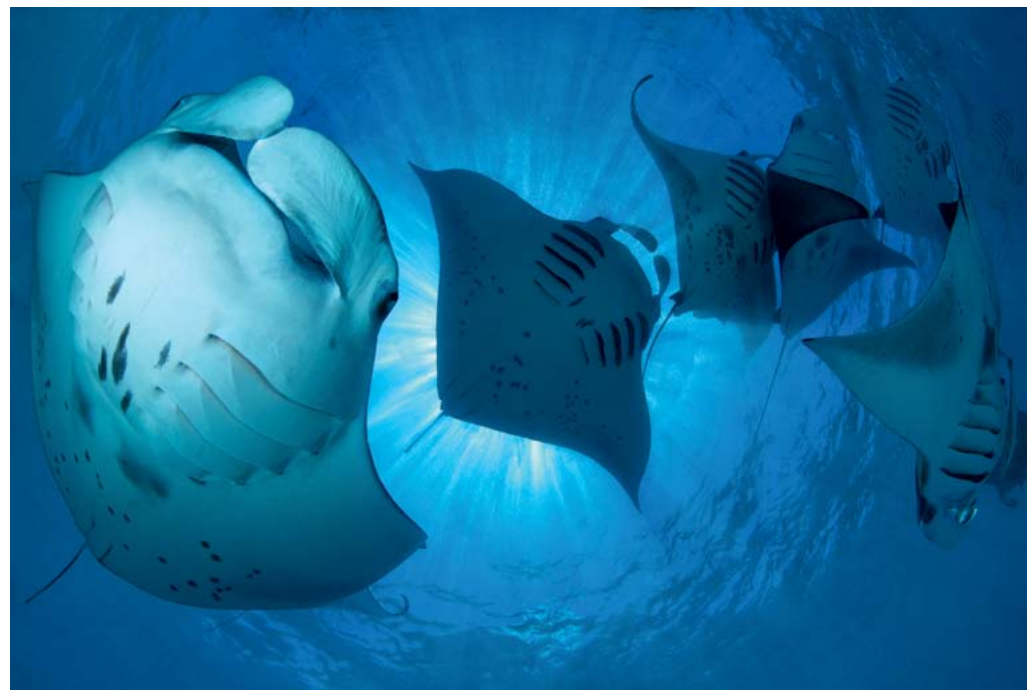

*Manta rays (Manta alfredi). Hanifaru Bay, Baa Atoll, Maldives, October 2011
Seacam Canon EOS 5D Mark II • Canon 8–15mm fisheye lens • two Ikelite DS125 strobes • 1/320 s • f/9 • ISO 50 • flash at full power*

of, and judged solely on its merits as an underwater photograph.

This review will finish, oddly, at the beginning. In Ernie Brooks' foreword he mentions his own mentors who shaped not only his enthusiasm and photographic skills, but passion, love and care for the marine eco-system. In Ernie's case he cites Hans Hass in that role, but aptly Ernie predicts that Tobias will assume

that role to many aspiring underwater photographers in the future. To be honest, I would have to agree with Ernie on this point, and would further argue that actually that future is not too far away for Tobias.

Dan Bolt

www.underwaterpics.co.uk

www.rockynook.com/shop/photography/underwater-photography

www.uwpmag.com

Guidelines for contributors

The response to UwP has been nothing short of fantastic. We are looking for interesting, well illustrated articles about underwater photography. We are looking for work from existing names but would also like to discover some of the new talent out there and that could be you! UwP is the perfect publication for you to increase your profile in the underwater photography community.

The type of articles we're looking for fall into five main categories:

Uw photo techniques - Balanced light, composition, etc

Locations - Photo friendly dive sites, countries or liveaboards,

Subjects -, Anything from whale sharks to nudibranchs in full detail

Equipment reviews - Detailed appraisals of the latest equipment

Personalities - Interviews/features about leading underwater photographers

**If you have an idea for an article,
contact me first before putting pen to paper.
E mail peter@uwpmag.com**

How to submit articles

To keep UwP simple and financially viable, we can only accept submissions by e mail and they need to be done in the following way:

1. The text should be saved as a TEXT file and attached to the e mail

2. Images must be attached to the e mail and they need to be 144dpi

Size - Maximum length 20cm i.e. horizontal pictures would be 20 cm wide and verticals would be 20cm.

File type - Save your image as a JPG file and set the compression to "Medium" quality. This should result in images no larger than about 120k which can be transmitted quickly. If we want larger sizes we will contact you.

3. Captions - **Each and every image MUST have full photographic details** including camera, housing, lens, lighting, film, aperture, shutter speed and exposure mode. These must also be copied and pasted into the body of the e mail.

Parting Shots

Death of a Princess

In British waters we are blessed with an abundance of shipwrecks to dive but the condition of all of them is deteriorating as the years roll by. It is doubly sad when we lose a shipwreck almost overnight but that is what happened to the Viking Princess near Plymouth in the southwest of the UK during the winter storms of 2014.

The Viking Princess was a decommissioned trawler which sank under tow and had been partly salvaged over the years but large sections of her still remained intact and provided a really useful backdrop for photography in about 17 metres (55 feet) where currents were rarely a problem. There were a couple of large congers which inhabited the engine room and a large shoal of fish usually decorated the stern. She was mostly open and very easy and safe to enter. Her exposed framework made for great shapes for fisheye lenses to bend and exaggerate. In short she was a really great dive and was usually blessed with above average visibility.

I should have cottoned on to what I was about to see when the telltale jump on the echo sounder never happened. I put it down to my being slightly off position and kitted up with my usual photographic enthusiasm. The viz was very good that day but 6 weeks earlier we had had one of the most severe and prolonged winter storms in recent history. Waves of over 15 metres (50 feet) were recorded and several navigation buoys were 'repositioned' with one actually being totally wrecked.



All shots are video frame grabs from a Panasonic GX7 in a Nauticam housing with 14-42 EZ lens with an external INON UWL100 with dome port. The bottom two were taken with a GreenWater Magic filter :-)

I should have put two and two together for, as I've already said, the Viking Princess lay in just 17 metres of water.

The scene which greeted me as I descended the anchor chain was totally alien. There was very little to recognise except large areas of flattened metal and a seabed strewn with new rocks and small boulders. Nothing of the wreck stood higher than 1 metre (3 feet) and the shoal of fish were nowhere to be seen. I doubt very much if the congers has survived as it must have been like being in a giant pebble (rock) dashing machine for several days.

It's very sad when you lose such a useful

photographic asset because it's gone forever. I guess the only consolation is that the images of her will still remain.

RIP Viking Princess.

Peter Rowlands
peter@uwpmag.com

**Do you have a shot which has a story within a story?
If so e mail it with up to 500 words of text
and yours could be the next Parting Shot.**
peter@uwpmag.com